

**CAMANCHE CITY COUNCIL AGENDA**  
**6:00 P.M. – CAMANCHE CITY HALL 818-7<sup>th</sup> Avenue**  
**TO ATTEND BY PHONE: 1-717-275-8940 ACCESS CODE: 289 8487**  
**ATTEND VIA INTERNET: <https://hello.freeconference.com/conf/call/2898487>**  
**(PLACE YOUR PHONE ON MUTE UNTIL PUBLIC COMMENTS)**  
**DECEMBER 19, 2023**

**Roll Call**

**Moment of Silent Prayer**

**Pledge of Allegiance**

**Approval of Agenda**

**Oath of Office – Mayor Austin Pruet**

**Oath of Office – Councilmembers Tom Klahn and Wesley Farrell**

**Visitor: Kristyl McDaniel, CPA, CGFM, Winkel Parker & Foster, CPA PC – FY2023 Audit Report**

**Public Comments on Agenda Topics-State Your Name and Address (3 Minute Limit)**

**Consent Agenda:**

- 1) Approve Minutes from Council meeting held on December 5, 2023
- 2) Approve bills and claims as submitted
- 3) Accept City Clerk/Treasurer's Report for November 2023
- 4) Approve renewal of Class B Retail Alcohol License as submitted by Kwik Trip, Inc. dba Kwik Star #632 effective 02/08/2024
- 5) Accept Resignation from Janeen Reuter, Library Board, effective December 7, 2023
- 6) Receive, accept and place on file draft minutes from the Library Board meeting on December 6, 2023
- 7) Receive, accept and place on file draft minutes from the Park and Recreation Commission meeting on December 11, 2023
- 8) Accept and place on file the report of Library Board Liaison Bowman
- 9) Accept and place on file the Auditor's Report for Fiscal Year 2023
- 10) Approve TIF Payment RJ Edens Rental Property \$53,930.13
- 11) Approve TIF Payment Cross Roads Land Development, L.L.C. \$13,959.88

**Unfinished Business:**

- 1) Renewal of 28E Agreement Concerning Collaborative Lobbying Effort by and Between Governmental Entities and Cooperative Entities in Clinton County, Iowa (Kida)
- 2) Presentation from ABM for Water Meter and Energy Proposal

**New Business:**

- 1) Resolution calling for a Public Hearing to Re-Zone certain portions of land currently designated M-2/M-3 Heavy Industrial and Ab Agricultural Rural as M-RE Renewable Energy Overlay
- 2) Approve City Engineers Shive-Hattery to administer bid process for the following projects
  - a. Gravel Sub-Base extension of Edens Ave

- b. Deep Well Construction on Parcel ID 1019552000
- 3) Resolution 20-37 Establishing a Policy for the Selling of Right of Way on Public Avenues where 100 foot Right of Way exists
  - 4) Police Station/Fire Station back parking lot and Police Station HVAC (Schmitz)
  - 5) Accept Resignation, effective December, 16, 2023, from Officer Tyson, Camanche Police Department (Schmitz)
  - 6) Authorize Chief Schmitz to fill vacancy in PD (Schmitz)
  - 7) Camanche Police Department November 2023 Report (Schmitz)

**Communication from City Attorney**

**Communication from City Administrator**

**Communication from Mayor**

**Communication from City Council Members and Department Heads**

**Public Comments-State Your Name and Address (3 MINUTE LIMIT)**

**Council Members Requests for Placement of Matters on Future Agendas**

**Adjourn**

**Work Session Budget FYE2025**

**Board Vacancies – None**

City of Camanche  
December 5, 2023

The City Council of the City of Camanche, Iowa met in regular session December 5, 2023, at 6:00 p.m. at Camanche City Hall. Present on roll call: Mayor Pruett presiding, and Council members Bowman, Rolston, Schnoor and Varner. Absent: Council member Weller. Also present were City Attorneys John Frey and Braydon Roberts, City Administrator Andrew Kida and Department Heads Evans (online, left at 6:40 p.m.), Pewe, Schmitz, Schutte and Schneider.

A moment of silent prayer was observed. Mayor Pruett led the Pledge of Allegiance.

Moved by Councilman Bowman second by Councilman Rolston, to approve the agenda. On roll call – all Ayes.

Visitor Rhonda Hugunin, 811 1<sup>st</sup> Street, was on the agenda regarding the Purchase of 20 FT R.O.W. for Garage Build. Her husband, Bill Hugunin, handed out a proposal to the Councilmembers, Mayor, City Administrator and City Attorneys. He then read his prepared statement, which stated they contacted City Administrator Kida and Building Inspector Teagarden who advised them to approach the Council with their request. They want to add a 30 feet deep garage to the street side of the property and add a second story to their home. They want to be able to park two vehicles in the garage and move appliances and mechanical items out of their basement and to keep items safe from flooding. Councilman Bowman said he met with the Hugunins and thinks it is a reasonable request. However, our current Resolution allows for the purchase of Right-Of-Way on Avenues but not Streets in that area of the City. Councilman Varner does not see a problem and Councilman Schnoor does not see a problem, being on the river side of the street. Kida advised that, if Council is going to change the policy, they should make the change on all the Streets. Something to consider—in the future, do you see the possibility of adding curb and gutter for storm sewer? Kida pointed out the setbacks of the current structures is already kind of jagged. It was agreed to review the policy to make sure it fits for all the houses. This will be on the next agenda.

Moved by Councilman Varner, second by Councilman Bowman to approve the Consent Agenda, which covered the following: Approve minutes from the Council meeting held on November 21, 2023; approve Abstract No. 837 which includes the following:

AIR CONTROL INC	LIBRARY FURNACE REPAIR	746.60
ALLIANT ENERGY	GAS SERVICE	1,035.27
UMB BANK NA	BOND INT-9 ST,W BLVD,SEWER,ANAM	72,346.88
CAMANCHE VOL FIRE DEPT	MONTHLY MAINTENANCE,SUPPLIES	519.98
CENTER POINT LARGE PRINT	LARGE PRINT BOOKS	197.32
CLINTON HUMANE SOCIETY	1 DOG, 4 DAYS; 2 CATS, 3 DAYS	250.00
CLINTON PRINTING COMPANY	FALL NEWSLETTER,PD BUSN CARDS	563.00
CLINTON NATIONAL BANK	FED/FICA TAX WITHHOLDING	13,107.48
CLINTON NATIONAL BANK	COMMUNITY CENTER LOAN INTEREST	3,349.49
GWORCS	ADD 50 PUBLIC USERS-FRONT DESK	398.00
EMER MEDICAL PRODUCTS INC	AMBULANCE SUPPLIES	1,361.18
HOME DEPOT CREDIT SERVICE	WATER, PAPER PROD, FLAG HRDWRE	139.24
IOWA ONE CALL	85 ONE CALL LOCATES	76.50
VOYA	457 PLAN DEDUCT	1,814.00
IPERS	IPERS	8,402.30
KWIK TRIP/KWIK STAR STORE	277.909 G POLICE; 267.76 G P WORKS	1,866.39
	15.954 G FIRE DEPT; 44.92 G CEM	
MEDIACOM	INTERNET	450.00
A. C. MCCARTNEY	SEAL FOR PUBLIC WORKS BOBCAT	35.86
MICROMARKETING LLC	CDS	43.99
MIDAMERICAN ENERGY CO	ELECTRIC SERVICE	3,614.66
MIDWEST RADAR & EQUIP	RECERTIFY RADAR EQUIPMENT-PD	280.00
JEFFREY MOORE	REIMB SPSE EXP IN LIEU OF INS	2,000.00
MUNICIPAL FIRE & POLICE	MUNICIPAL PENSION	12,702.75
O'REILLY AUTOMOTIVE INC	WIPER BLADE-PLOW;SHOP SUPPLIES	154.95
THE PENWORTHY COMPANY	BOOKS/DVDS	870.83

LIFE INSURANCE	LIFE INSURANCE PREMIUMS	1,238.97
QC ANALYTICAL SERVICES	SAMPLE ANALYSIS	233.00
SANDRY FIRE SUPPLY LLC	FIRE REPAIR/MAINTENANCE	100.00
DAVE SCHUTTE	REIMB MEAL-CHIEF'S CONFERENCE	41.67
STANARD & ASSOCIATES INC	FF/PARAMEDIC TESTS	80.00
TREASURER STATE OF IOWA	STATE WITHHOLDING TAX	5,234.31
US CELLULAR	PD CELL PHONES,MOBILE 311 DATA	613.10
MICHAEL YACKSHAW	REIMBURSE BOOT ALLOWANCE	206.97
WINDSTREAM	PHONE/LONG DISTANCE	307.75
DEPENDABLE DRAIN & PLUMB	REPAIRS-TREATMENT PLANT	3,326.11
PREMIER PARTS INC	CAMANCHE DAYS FENCE INST. PART	26.44
CENTURYLINK	TELEPHONE EXPENSE	149.92
OVERDRIVE	E-BOOKS	387.71
TUMBLEWEED PRESS INC.	SUBSCRIPTION-TUMBLEBOOK	499.00
BLUE CROSS BLUE SHIELD	HEALTH INSURANCE PREMIUMS	21,772.82
AFLAC	AFLAC - PRETAX	465.00
PATC	TRAINING-OFFICER PARKS	595.00
CONTINUOUS TOUCH, LLC	SIP TRUNKING	150.53
CASEY'S GENERAL STORES	88.96 G FD; 78.83G AMB; 68.67G PD; 10.47G S JET; 25.31G BLDG INSPECT	1,062.38
SPARKLEAN	NOV23 CLEAN CHALL,CCTR,LIB,PD,PW	975.00
TOM MCMANUS BACKHOE	GRAVE-GREVE	400.00
HSA ACCOUNTS	HSA- EMPLOYEES	1,800.00
PLATINUM INFORMATION SERV	ADOBE LICENSE-POLICE DEPT	573.47
TONI SCHNEIDER	WELLNESS REIMBURSEMENT	197.60
NATHAN CAMPIE	REIMBURSE CLOTHING ALLOWANCE	83.44
DINGES FIRE COMPANY	LETTER PATCHES-AMBULANCE DEPT	490.00
REPUBLIC SERVICES	NOV 23 CITY COLLECTION	31,078.90
THE SHREDDER	ON-SITE SHREDDING	240.00
CLINTON COUNTY AUDITOR	2023 CITY ELECTION	1,667.96
STRYKER MEDICAL	AMBULANCE REPAIRS/MAINTENANCE	730.15
MIDWEST GROUP BENEFITS	WEEKLY CLAIMS	1,831.00
GEMT	STATE SHARE-GEMT-DEC 2023	1,217.79
GREAT WESTERN SUPPLY CO	PAPER PRODUCTS-COMM CTR/C HALL	330.01
O.T.R. TIRE	TIRE REPAIR-SQUAD CAR	25.00
CINTAS	TOWELS,RUGS-PW;UNIF-PEWE	35.12
TEMP ASSOCIATES-IOWA, INC	LIBRARY-SPRINGER/ZAMORA 11/26	1,699.44
KELLI ELLIOTT	REIMBURSE JOB FAIR EXPENSES	76.98
AIRGAS USA, LLC.	CYLINDER RENTAL	10.08
CITIZENS FIRST BANK	PH III/EQUIPMENT LOAN INTEREST	5,843.81
SHAUNA TEGELER	REIMBURSE WELLNESS	40.00
ALTORFER, INC.	GENERATOR RENTAL-WELL #5	2,575.00
PCC AMBULANCE BILLING SER	OCT 23 AMB BILLING SERVICE	1,246.66
BOUND TREE MEDICAL, LLC	AMBULANCE SUPPLIES	73.28
DEPOSIT REFUNDS	REFUND DATE 11/28/2023	211.57
PAYROLL CHECKS	PAYROLL CHECKS ON 11/22/2023	53,663.22
PAYROLL CHECKS	PAYROLL CHECKS ON 12/01/2023	1,634.75
	CLAIMS TOTAL	271,567.58
	GENERAL FUND	110,469.96
	LIBRARY FUND	10,405.24
	PARKS FUND	2,144.19
	CEMETERY FUND	3,824.90
	ROAD USE FUND	7,429.93
	EMPLOYEE BENEFIT FUND	(990.06)
	POLICE & FIRE PENSION FUND	80.00
	DEBT SERVICE FUND	81,540.18
	PFAS FUND	5,342.12
	WATER UTILITY FUND F	11,775.01
	SEWER UTILITY FUND	7,661.64
	LANDFILL/GARBAGE FUND	31,884.47

Receive, accept and place on file draft minutes from the Park and Recreation Commission meetings on November 13, 2023 and November 27, 2023; Receive, accept and place on file draft minutes from the Library meeting on November 1, 2023. On roll call – all Ayes.

Kida led a discussion on the Renewal of 28E Agreement Concerning Collaborative Lobbying Effort by and Between Government Entities and Cooperative Entities in Clinton County, Iowa. He said our contribution is \$1,300.00 and feels we should get more feedback. Councilman Bowman said he wonders what we are getting for the amount we are paying and is not real keen on it. He also does not want Camanche to be a pariah if we do not participate. Kida recommends asking them to come to the next meeting to present. After further discussion, it was decided to table this item for the next agenda. Kida will send something to Grow Clinton asking them to present to the Council.

With the new Solar Ordinance, a permit fee structure is needed. Kida used what Cedar Rapids is using to create this Resolution; it is similar to Clinton County's. Mayor Pruett read a Resolution Establishing Building Permit Fees for Solar Improvements in the City of Camanche.

Moved by Councilman Bowman, second by Councilman Varner to Adopt a Resolution Establishing Building Permit Fees for Solar Improvements in the City of Camanche. On roll call – all Ayes.

A proposal from AccuJet to video and clean sanitary sewer lines from 3<sup>rd</sup> Street to the river was discussed. Kida said this company is very affordable, although the mobilization fee is a little high. The plan is to do half of the lines this fiscal year and the other half next fiscal year. This will help us to understand what we are dealing with in this older part of town. The discussion included the collapses that occurred during the 2019 flood and the damage caused by infiltration. The plan is to have the mains lined with something that will prevent infiltration.

Moved by Councilman Bowman, second by Councilman Schnoor to accept the proposal from AccuJet \$25,171.72, to video and clean sanitary sewer lines from 3<sup>rd</sup> Street to the river. On roll call – all Ayes.

Councilman Bowman led a discussion regarding Planning and Zoning Board Member Attendance. He is the Liaison for this Board and said that one meeting, 5 of the 7 members did not show. Maybe this should be a 5 member Board instead of 7. The membership could be reduced through attrition. Bowman would like to see a reminder to go out to these folks that if they cannot make it to the meeting to let Andrew know. Further discussion resulted in the decision to send out a letter to all Board and Commission members to let them know how much we appreciate them and their service to the City and also to remind them to let someone know if they are unable to attend their respective meetings.

Chief Schmitz addressed the Council regarding increasing the speed limit on 9<sup>th</sup> Street, from 19<sup>th</sup> Avenue to the bypass from 25 mph to 30 mph. It was agreed to place an Ordinance amendment on the next Agenda for consideration.

Chief Schutte presented the November 2023 Fire Department Report.

Councilman Schnoor thanked everyone, saying they have been great to work with. We have been through a lot in the last 4 years and wants the new members to keep the good work going. Public Works Director Pewe reported that street sweeping is underway, 9<sup>th</sup> Street is wrapping up and 19<sup>th</sup> Avenue construction should begin Thursday or Friday.

Mayor Pruett called for public comments; there were none.

Mayor Pruett adjourned the meeting at 6:52 p.m.

Austin Pruett  
Mayor

Toni Schneider  
City Clerk/Treasurer

CLAIMS REPORT

VENDOR	REFERENCE	AMOUNT	CHECK #	CHECK DATE
ACCESS SYSTEMS	COPIES-POLICE DEPARTMENT	107.72	92942	12/19/2023
ACCESS SYSTEMS LEASING	CITY HALL, LIBRARY COPIER LEASE	472.86	92943	12/19/2023
AIR CONTROL INC	FURNACE REPAIRS-LIBRARY	380.22	92944	12/19/2023
AIRGAS USA, LLC.	CYLINDER RENTAL	9.75	92945	12/19/2023
AMAZON CAPITAL SERVICES INC.	LIBRARY BOOKS,DVDS,SUPPLIES	810.47	92946	12/19/2023
BOUND TREE MEDICAL, LLC	EMS OPERATING SUPPLIES	63.92	92947	12/19/2023
BRENT BRIGHTMAN	NOV 23 AMBULANCE STIPEND	20.00	92913	12/8/2023
BRIAN PAUL WERNICK	NOV 23 AMBULANCE STIPEND	24.00	92914	12/8/2023
BWC EXCAVATING	VACUUM OUT 9TH ST LIFT STATION	2,771.00	92948	12/19/2023
CAMANCHE WATER WORKS	4TH QTR 2023 WATER/SEWER BILLS	596.46	92949	12/19/2023
CASEY'S BUSINESS MASTERCARD	62.18 GAL FD; 37.96 GAL PD; 43.97 GAL AMB; 24.01 GAL BLDG INSP	595.55	10319797	12/19/2023
CENTURYLINK	TELEPHONE EXPENSE	166.75	92950	12/19/2023
CHRISTIAN MARSH	NOV 23 PAID ON CALL	120.00	92915	12/8/2023
CINTAS	UNIFORM DEDUCT-PEWE	18.20	92910	12/8/2023
CINTAS	TOWELS,RUGS-PW,CH;UNIF-PEWE	85.11	92951	12/19/2023
CITY OF CLINTON	28E SEWER CONTRACT	24,000.00	92952	12/19/2023
CL CO AREA SOLID WASTE	YARD WASTE	77.44	92953	12/19/2023
CLINTON ACE HARDWARE	SHIP WATER SAMPLES	13.24	92954	12/19/2023
CLINTON COUNTY AUDITOR	2ND QTR FY24 PEANUT BUTTER	210.00	92955	12/19/2023
CLINTON HERALD	LEGAL PUBLICATIONS	464.11	92956	12/19/2023
CLINTON NATIONAL BANK	FED/FICA TAX WITHHOLDING	13,131.62	10319778	12/8/2023
COAST TO COAST COMPUTER PRODUC	LIBRARY COLORING BOOKS	207.08	92957	12/19/2023
CORY SNODGRASS	NOV 23 AMBULANCE STIPEND	36.00	92916	12/8/2023
CULLIGAN	WATER, DISP RENT- CITY HALL	47.45	92958	12/19/2023
DANNY WELLER	NOV 23 AMBULANCE STIPEND	180.00	92917	12/8/2023
DARYL YODER	REIMB CDL LICENSE	64.00	92918	12/8/2023
E C I A	MEMBERSHIP DUES FY24 2ND INSTALL	1,690.90	92959	12/19/2023
EASTERN IA LIGHT & POWER	SECURITY LIGHT-ANAMOSA, 9TH ST	119.31	92960	12/19/2023
EASTERN IOWA COMM COLLEGES	ACLS/BLS INSTRUCTOR-SCHUTTE	18.00	92961	12/19/2023
EMER MEDICAL PRODUCTS INC	AMBULANCE SUPPLIES	416.70	92962	12/19/2023
ERIC MICHAEL DAU	NOV 23 PAID ON CALL	240.00	92919	12/8/2023
FREY, HAUFE & CURRENT PLC	LEGAL SERVICES, PFAS-NOV 2023	4,895.55	92963	12/19/2023
GAYLON PEWE	WELLNESS REIMBURSEMENT	105.93	92920	12/8/2023
GENESIS OCCUPATIONAL HEALTH	MEDICAL DIRECTOR SERVICES	156.25	92964	12/19/2023
GREAT WESTERN SUPPLY CO	TISSUES-CITY HALL	111.89	92965	12/19/2023
GREGORY EDWARD NELSON	NOV 23 AMBULANCE STIPEND	144.00	92921	12/8/2023
gWORKS	W-2S, 1099 FORMS,ENVELOPES	245.59	92966	12/19/2023
HAROLD TEAGARDEN	REIMBURSE EMT TEST	134.00	92922	12/8/2023
HAWKINS, INC	100 GAL AZONE-WATER DEPARTMENT	359.24	92967	12/19/2023
HOME DEPOT CREDIT PLAN	TAPE-BUILDING INSPECTOR	9.77	10319798	12/19/2023
HOME DEPOT CREDIT PLAN	CONCRETE-SIGNS;MOUSE TRAPS-PW	57.45	10319799	12/19/2023
HOME DEPOT CREDIT PLAN	STORAGE BOXES-DOG PEN	58.76	10319800	12/8/2023
HOME DEPOT CREDIT PLAN	BATTERIES-CITY HALL	29.15	10319801	12/8/2023
HSA ACCOUNTS	HSA- EMPLOYEES	1,550.00	10319780	12/8/2023
IOWA LEAGUE OF CITIES	ROLSTON-VIRTUAL MLA REGISTRATION	220.00	92968	12/19/2023
IOWA POLICE CHIEFS ASSOC	MEMBERSHIP-CHIEF RICH SCHMITZ	125.00	92969	12/19/2023

JACOB VANZUIDEN	WELLNESS REIMBURSEMENT	89.50	92970	12/19/2023
JEFFREY D HACKNEY	NOV 23 AMBULANCE STIPEND	12.00	92923	12/8/2023
JENNIFER BIELEMA	NOV 23 AMBULANCE STIPEND	108.00	92924	12/8/2023
JEREMIAH JACOBSEN	NOV 23 AMBULANCE STIPEND	40.00	92925	12/8/2023
JOHN LUND	NOV 23 AMBULANCE STIPEND	50.00	92926	12/8/2023
JORDAN STEVEN MOORE	NOV 23 AMBULANCE STIPEND	40.00	92927	12/8/2023
KWIK TRIP INC.	260.424 G PD; 31.389 G FD; 250.36 G PW 62.412 G AMB; 76.658 G CEMETERY	1,956.25	10319802	12/14/2023
KYLE STEVEN DEWITT	NOV 23 AMBULANCE STIPEND	24.00	92928	12/8/2023
LESLIE ELECTRIC SERVICES INC	WELLHOUSE #5 UPGRADE TO 400 AMP	17,445.00	92971	12/19/2023
MEDIACOM	INTERNET	135.56	92972	12/19/2023
MERCYONE, CLINTON, IA	OCT/NOV 23 PHARMACEUTICALS	105.00	92973	12/19/2023
MICHAEL BURMAHL	NOV 23 AMBULANCE STIPEND	36.00	92940	12/8/2023
MICHELLE ANN SOWLE	NOV 23 AMBULANCE STIPEND	80.00	92930	12/8/2023
MIDAMERICAN ENERGY CO	STREET LIGHTING	2,530.94	92974	12/19/2023
MIDWEST GROUP BENEFITS	MONTHLY SERVICE FEE	175.00	92975	12/19/2023
MIDWEST GROUP BENEFITS	WEEKLY CLAIMS	331.63	10319803	12/13/2023
MIDWEST GROUP BENEFITS	WEEKLY CLAIMS	818.02	10319804	12/6/2023
MUNICIPAL FIRE & POLICE	MUNICIPAL PENSION	13,289.19	10319779	12/8/2023
O'REILLY AUTOMOTIVE STORES INC	SILICONE-9TH ST LIFT STATION	18.99	92976	12/19/2023
OVERDRIVE	E-BOOKS,AUDIO BOOKS	139.99	92977	12/19/2023
PLATINUM INFORMATION SERVICES	ITSUPPORT,NETWORK MON,SPAMFLT	3,463.17	92978	12/19/2023
PLATINUM LEASING SERVICES, INC	LEASE 231-7 POWER EDGE SERVER	839.00	92979	12/19/2023
PLATINUM SMART INC.	DATA BACKUPS-DEC 23	400.00	92980	12/19/2023
POSITIVE PROMOTIONS, INC	SHIELD STICKERS-POLICE DEPT	330.95	92981	12/19/2023
POSTMASTER	4TH QTR WATER/SEWER BILLS	786.09	92941	12/11/2023
NAPA AUTO PARTS	PARTS-SEWER DEPT CHECK VALVES	199.36	92931	12/8/2023
PRESTO-X COMPANY	PEST CTRL-CCTR,LIB,CHALL,HIST BLDG	204.34	92982	12/19/2023
QC ANALYTICAL SERVICES LLC	SAMPLE ANALYSIS	233.00	92983	12/19/2023
QUILL CORPORATION	OFFICE SUPPLIES-CITY HALL	36.58	92984	12/19/2023
RILEY SOWLE	NOV 23 AMBULANCE STIPEND	20.00	92932	12/8/2023
RIVER VALLEY COOPERATIVE	TANK RENT-COMM GENERATOR 911	150.00	92985	12/19/2023
SANTA HOUSE/HOLIDAY HOUSE	PARK AND REC ANNUAL DONATION	500.00	92986	12/19/2023
SECRETARY OF STATE	RENEW NOTARY-SCHMITZ	30.00	92987	12/19/2023
SHALAYA AUSTIN	NOV 23 AMBULANCE STIPEND	36.00	92933	12/8/2023
SHIVE-HATTERY ENGINEERS	ENGINEERING-3M DRINKING WATER	23,415.98	92988	12/19/2023
SHUTTLEWORTH & INGERSOLL	PFAS ENVIRONMENTAL MATTERS	88.00	92934	12/8/2023
TEAM TWO INC	AMBULANCE BILLING-AUG/NOV 23	850.71	92989	12/19/2023
TEMP ASSOCIATES-IOWA, INC	LIBRARY-SPRINGER THRU 10/22/23	665.41	92935	12/8/2023
TEMP ASSOCIATES-IOWA, INC	LIBRARY-SPRINGER/ZAMORA 12/10	1,752.37	92990	12/19/2023
THOMAS FRANKLIN	NOV 23 AMBULANCE STIPEND	108.00	92936	12/8/2023
TODD POWERS	NOV 23 AMBULANCE STIPEND	12.00	92937	12/8/2023
TOM MCMANUS BACKHOE AND	GRAVE-NIE	400.00	92991	12/19/2023
ANTHONY RAYMOND BLOMME	NOV 23 AMBULANCE STIPEND	264.00	92938	12/8/2023
TREASURER STATE OF IOWA	NOV 23 SALES TAX	46.91	10319805	12/14/2023
TREASURER STATE OF IOWA	NOV 23 WATER EXCISE TAX	273.99	10319806	12/14/2023
TROY ALDERMAN	CLOTHING ALLOWANCE	54.56	92939	12/8/2023
	PAYROLL PAID ON 12/08/23	54,038.83		
	***** REPORT TOTAL *****	181,984.76		

CHECK NO	DATE	EMP NO	PAY TO THE ORDER OF	CHECK AMOUNT	CLEARED	VOIDED	MANUAL
1			CITIZEN'S FIRST BANK 073922762				
6607	12/08/2023	10800	JOE W TYSON	2630.04			
6608	12/08/2023	9500	HAROLD W TEAGARDEN	1423.37			
6609	12/08/2023	10400	GAYLON S PEWE	2075.79			
6610	12/08/2023	9600	JEFFREY R ANNEAR	249.52			
6611	12/08/2023	10900	JEFFREY J APLIN	327.05			
6612	12/08/2023	3900	MICHAEL G YACKSHAW	250.00			
6613	12/08/2023	3900	MICHAEL G YACKSHAW	1887.51			
6614	12/08/2023	4000	DARYL W YODER	1857.29			
6615	12/08/2023	7700	NATHAN P CAMPIE	125.00			
6616	12/08/2023	7700	NATHAN P CAMPIE	1493.40			
6617	12/08/2023	1800	WILLIAM J LODGE	425.00			
6618	12/08/2023	1800	WILLIAM J LODGE	333.00			
6619	12/08/2023	1800	WILLIAM J LODGE	1670.59			
6620	12/08/2023	2800	RICHARD E SCHMITZ	1527.32			
6621	12/08/2023	2800	RICHARD E SCHMITZ	1250.00			
6622	12/08/2023	3200	KELLI J ELLIOTT	1654.46			
6623	12/08/2023	3200	KELLI J ELLIOTT	1238.34			
6624	12/08/2023	8600	CORY J SNODGRASS	1235.00			
6625	12/08/2023	8600	CORY J SNODGRASS	2043.67			
6626	12/08/2023	8700	ANDREW M WEINGART	2901.54			
6627	12/08/2023	9700	BRITTNEY R PARKS	2790.97			
6628	12/08/2023	1900	JEFFREY D MOORE	3232.48			
6629	12/08/2023	3000	DAVID C SCHUTTE	2644.98			
6630	12/08/2023	3300	JAMES F SOWLE	400.00			
6631	12/08/2023	3300	JAMES F SOWLE	1819.93			
6632	12/08/2023	9100	MITCHELL L JAHNS	2530.23			
6633	12/08/2023	9200	JACOB M VANZUIDEN	1100.00			
6634	12/08/2023	9200	JACOB M VANZUIDEN	600.00			
6635	12/08/2023	9200	JACOB M VANZUIDEN	816.53			
6636	12/08/2023	700	ANNA L EVANS	1543.00			
6637	12/08/2023	5100	NANCY J MCDUGALL	580.11			
6638	12/08/2023	10000	SHAINA J PAARMANN	438.02			
6639	12/08/2023	9400	ROB J PUTMAN	601.10			
6640	12/08/2023	7000	ANDREW S KIDA	700.00			
6641	12/08/2023	7000	ANDREW S KIDA	1938.83			
6642	12/08/2023	7300	TONI L SCHNEIDER	55.00			
6643	12/08/2023	7300	TONI L SCHNEIDER	40.00			
6644	12/08/2023	7300	TONI L SCHNEIDER	185.00			
6645	12/08/2023	7300	TONI L SCHNEIDER	1392.94			
6646	12/08/2023	10700	SHAUNA E TEGELER	1003.50			
6647	12/08/2023	5000	CHRISTY J SCHUTTE	40.00			
6648	12/08/2023	5000	CHRISTY J SCHUTTE	150.00			
6649	12/08/2023	5000	CHRISTY J SCHUTTE	1169.26			
6650	12/08/2023	6600	TROY F ALDERMAN	1669.06			
			BANK TOTAL	54038.83			
			REPORT TOTAL	54038.83			



**CLAIMS REPORT  
CLAIMS FUND SUMMARY**

FUND	NAME	AMOUNT
001	GENERAL	88,197.77
002	LIBRARY	7,656.60
003	PARKS	1,688.22
004	CEMETERY	2,028.23
110	ROAD USE	6,057.88
321	9TH STREET PROJECT	3,554.00
333	PFAS	35,729.59
600	WATER UTILITY FUND	6,643.22
610	SEWER UTILITY FUND	29,744.38
670	LANDFILL/GARBAGE	684.87
-----		
	TOTAL FUNDS	181,984.76

**BALANCE SHEET**  
**CALENDAR 11/2023, FISCAL 5/2024**

ACCOUNT NUMBER	ACCOUNT TITLE	MTD BALANCE	YTD BALANCE
001-000-1110	CASH ON HAND-GENERAL	20,855.62	597,932.76
001-000-1119	CASH - INSURANCE FUND	42.90-	69,105.68
002-000-1110	CASH-LIBRARY	14,045.70	56,833.54
003-000-1110	CASH-PARKS AND REC	4,415.92	33,995.51
004-000-1110	CASH-CEMETERY	1,945.54	6,657.42
110-000-1110	CASH-ROAD USE	2,403.23	280,376.22
112-000-1110	CASH - EMPLOYEE BENEFIT	3,642.13	140,478.95
117-000-1110	CASH - CIVIL SVC. RET. EX	5,388.37	56,724.62
125-000-1110	CASH - TIF	.00	50,793.52
126-000-1110	CASH-CROSS TIF-E RIVER CT	2,130.69	13,549.38
145-000-1110	CASH-LOW/MODERATE HOUSING	.00	71,489.71
146-000-1110	CASH-CROSS LMI-E RIVER CT	1,305.91	33,373.54
160-000-1110	CASH - ECONOMIC DEVELOP.	.00	.00
167-000-1110	CASH - TRUST & AGENCY	.00	.00
200-000-1110	CASH-DEBT SERVICE	25,288.22-	273,983.43
312-000-1110	CASH - 9TH AV/ANAMOSA/21ST ST	.00	6,174.35
315-000-1110	CASH-CITY HALL EXPANSION PROJ	.00	.00
315-750-1110	CASH	.00	.00
316-000-1110	CASH-21ST ST CULVERT	.00	.00
317-000-1110	CASH	.00	.00
318-000-1110	CASH-AMERICAN RESCUE PLAN	.00	128,323.60
319-000-1110	CASH PHASE III SIP/EQUIPMENT	.00	.00
320-000-1110	CASH-ROUNDAABOUT PROJECT	.00	35,929.83-
321-000-1110	CASH-9TH STREET PROJECT	30,195.87-	300,408.00
325-000-1110	CASH-ACC/GCC WATER LINE EXTENS	2,175.00-	116,950.00
333-000-1110	CASH-PFAS-3M	52,827.01-	471,969.56
334-000-1110	CASH-TRAIN DEPOT PROJECT	14,500.00-	8,850.00
600-000-1110	CASH-WATER	27,397.78-	562,554.53
600-000-1111	WATER DEPOSITS	238.43	194,066.61
610-000-1110	CASH-SEWER	28,410.49-	111,720.68
670-000-1110	CASH-GARBAGE	60,588.38-	7,897.67
	CASH TOTAL	185,054.11-	3,558,279.45
302-000-1111	CASH-CDBG	.00	.00
	CASH-CDBG TOTAL	.00	.00
001-000-1120	PETTY CASH - CLERK	.00	200.00
002-000-1121	PETTY CASH - LIBRARY	.00	325.00
600-000-1120	PETTY CASH	.00	200.00
	PETTY CASH TOTAL	.00	725.00
002-000-1160	LIBRARY SAVINGS	41.60	17,200.74
	LIBRARY SAVINGS TOTAL	41.60	17,200.74

**BALANCE SHEET**  
**CALENDAR 11/2023, FISCAL 5/2024**

ACCOUNT NUMBER	ACCOUNT TITLE	MTD BALANCE	YTD BALANCE
001-000-1161	BARGAIN UNIT WELLNESS PRG	.00	.00
320-000-1161	CD	.00	.00
321-000-1161	9TH ST CFB CD #36432	.00	.00
	WELLNESS SAVINGS TOTAL	.00	.00
167-000-1160	ROBERT HOWSON EST TRUST	.79	326.58
	ROBERT HOWSON SAVINGS TOTAL	.79	326.58
167-000-1161	PERP CARE TRUST SAVINGS	2.80	1,156.11
	PERPETUAL CARE SAVINGS TOTAL	2.80	1,156.11
167-000-1170	PERP CARE TRUST CD#19810	.00	85,000.00
321-000-1170	CD #36432	.00	.00
	CD #01875 TOTAL	.00	85,000.00
001-000-1170	GEN P.W.D. EQ C.D.#37804	.00	6,297.88
001-000-1171	GEN POL EQ PUR C.D.#37804	.00	97,306.05
001-000-1172	GEN FIRE EQ C.D. #37804	.00	351,047.62
001-000-1173	GENERAL C HALL-CD#37804	.00	5,646.58
001-000-1174	AMBULANCE EQUIP-CD#37804	.00	72,839.96
610-000-1171	SEWER EQ. PUR. C.D.04250	.00	.00
	CD #01875 TOTAL	.00	533,138.09
002-000-1176	EQUIPMENT RESERVE-CD19463	.00	24,297.30
	CD #01875 TOTAL	.00	24,297.30
001-000-1177	GEN CD #17954 VACATION/SICK	.00	87,984.91
	CD #02337 TOTAL	.00	87,984.91
001-000-1178	GENERAL CD 15758	.00	.00
	CD #01875 TOTAL	.00	.00
003-000-1179	RECREA. RIP-RAP CD#04965	.00	.00
004-000-1175	CEMETERY TRACTOR CD19463	.00	10,177.17

**BALANCE SHEET**  
**CALENDAR 11/2023, FISCAL 5/2024**

ACCOUNT NUMBER	ACCOUNT TITLE	MTD BALANCE	YTD BALANCE
	CD #01883 TOTAL	.00	10,177.17
003-000-1176	RECRE. MOWER CD19463	.00	59,236.23
110-000-1170	R.U.T. C. D. #07997	.00	.00
	CD #01883 TOTAL	.00	59,236.23
600-000-1170	WATER METER C.D. #19802	.00	99,890.48
	CD #02303 TOTAL	.00	99,890.48
600-000-1171	WATER UT RES CD 07450	.00	.00
	CD #07450 TOTAL	.00	.00
001-000-1179	KATSIS MEMORIAL FUND-CD #00976	.00	.00
610-000-1170	SEW NE CO FUT DS #80644	.00	.00
	CD #00976 TOTAL	.00	.00
600-000-1172	WATER MAINTENANCE-CD #19422	.00	109,343.02
	CD #01289 TOTAL	.00	109,343.02
	TOTAL CASH	185,008.92-	4,586,755.08

# OUTSTANDING TRANSACTION REGISTER

OPEN

MOD CODE	BANK NO	NAME	NUMBER	DATE	PERIOD	VEND/EMPL	OTHER NUMB	DEPOSITS	CHECKS AND WITHDRAWALS	RECONCILING	VOIDED	MANUAL
1 CITIZEN'S FIRST BANK			STATEMENT DATE: 11/30/2023									
RM DEP	86120	11/30/23	05/24	DEPOSIT				727.32				
BK DEP	86129	11/30/23	05/24	CR Card Deposit				245.45				
PR CHK	83576	1/02/20	07/20	HOUZENGA, DAMIE					.93			
UB CHK	86229	7/01/21	01/22	GRAMS KENDALL					1.55			
AP CHK	86271	7/12/21	01/22	JESSE SCHNEEBERGER					15.00			
AP CHK	86406	8/06/21	02/22	DREW HACKNEY					15.00			
AP CHK	86420	8/06/21	02/22	JESSE SCHNEEBERGER					10.00			
AP CHK	86555	9/07/21	03/22	JESSE SCHNEEBERGER					10.00			
AP CHK	87481	2/15/22	08/22	JESSE SCHNEEBERGER					25.00			
AP CHK	87575	3/04/22	09/22	JESSE SCHNEEBERGER					5.00			
AP CHK	87584	3/04/22	09/22	RILEY SOWLE					60.00			
AP CHK	87749	4/08/22	10/22	JESSE SCHNEEBERGER					30.00			
AP CHK	87901	5/17/22	11/22	JESSE SCHNEEBERGER					5.00			
AP CHK	87923	5/17/22	11/22	RILEY SOWLE					60.00			
AP CHK	88025	6/10/22	12/22	JESSE SCHNEEBERGER					5.00			
AP CHK	88035	6/10/22	12/22	RILEY SOWLE					36.00			
AP CHK	88232	7/19/22	01/23	JESSE SCHNEEBERGER					5.00			
AP CHK	88254	7/19/22	01/23	RILEY SOWLE					36.00			
AP CHK	88794	11/02/22	05/23	MICHAEL ANDERSON JR					12.00			
AP CHK	88951	12/08/22	06/23	ERIC DAU					40.00			
UB CHK	88972	12/09/22	06/23	KIMMER SARAH					9.82			
UB CHK	88973	12/09/22	06/23	O'NEAL MARCIA					1.98			
AP CHK	89146	1/13/23	07/23	MORGAN BUTT					24.00			
AP CHK	89300	2/15/23	08/23	TRISH ANN ANDERSON					20.00			
UB CHK	89559	4/11/23	10/23	NILES BRADLEY					8.69			
AP CHK	89578	4/11/23	10/23	MORGAN BUTT					24.00			
UB CHK	89867	6/08/23	12/23	COOK THOMAS J					78.03			
UB CHK	89869	6/08/23	12/23	HOENICKE HANNAH					53.32			
UB CHK	89994	6/27/23	12/23	CARBAJAL JESSE					117.90			
AP CHK	92171	7/18/23	01/24	RILEY SOWLE					160.00			
AP CHK	92317	8/04/23	02/24	MORGAN BUTT					12.00			
AP CHK	92477	9/11/23	03/24	MICHAEL BURMAHL					72.00			
AP CHK	92484	9/11/23	03/24	TODD POWERS					24.00			
AP CHK	92557	9/22/23	03/24	SECRETARY OF STATE					30.00			
AP CHK	92612	10/06/23	04/24	BRANDON SMITH					36.00			
AP CHK	92634	10/06/23	04/24	MORGAN BUTT					12.00			
AP CHK	92640	10/06/23	04/24	RILEY SOWLE					160.00			
AP CHK	92735	10/31/23	04/24	BRITTNEY PARKS					140.00			
AP CHK	92773	11/09/23	05/24	BRANDON SMITH					12.00			
AP CHK	92774	11/09/23	05/24	BRENT BRIGHTMAN					5.00			
AP CHK	92775	11/09/23	05/24	BRIAN WERNICK					24.00			
AP CHK	92776	11/09/23	05/24	CAMANCHE SCHOOLS					150.00			
AP CHK	92777	11/09/23	05/24	CHRISTIAN MARSH					220.00			
AP CHK	92780	11/09/23	05/24	DANNY WELLER					156.00			
AP CHK	92782	11/09/23	05/24	ERIC DAU					460.00			
AP CHK	92785	11/09/23	05/24	JEFFREY HACKNEY					12.00			
AP CHK	92786	11/09/23	05/24	JENNIFER BIELEMA					180.00			
AP CHK	92787	11/09/23	05/24	JEREMIAH JACOBSEN					80.00			
AP CHK	92789	11/09/23	05/24	JOHN LUND					20.00			
AP CHK	92791	11/09/23	05/24	MICHAEL BURMAHL					12.00			
AP CHK	92792	11/09/23	05/24	MICHELLE SOWLE					60.00			
AP CHK	92793	11/09/23	05/24	MORGAN BUTT					12.00			

# OUTSTANDING TRANSACTION REGISTER

OPEN

MOD CODE	BANK NO NAME			VEND/EMPL	OTHER NUMB	CHECKS AND		RECONCILING	VOIDED	MANUAL	
	NUMBER	DATE	PERIOD			DEPOSITS	WITHDRAWALS				
AP CHK	92795	11/09/23	05/24	RILEY SOWLE			80.00				
AP CHK	92796	11/09/23	05/24	SHALAYA AUSTIN			72.00				
AP CHK	92798	11/09/23	05/24	THOMAS FRANKLIN			180.00				
AP CHK	92799	11/09/23	05/24	TODD POWERS			60.00				
AP CHK	92800	11/09/23	05/24	TONY BLOMME			132.00				
AP CHK	92806	11/21/23	05/24	ALEXIS FIRE EQUIP CO INC			2,040.00				
AP CHK	92808	11/21/23	05/24	AXON ENTERPRISE, INC.			21,303.36				
AP CHK	92810	11/21/23	05/24	CENTURYLINK			1,135.80				
AP CHK	92811	11/21/23	05/24	CINTAS			136.57				
AP CHK	92817	11/21/23	05/24	FREY, HAUFE & CURRENT PLC			9,121.25				
AP CHK	92821	11/21/23	05/24	IA DEPT OF PUBLIC SAFETY			300.00				
AP CHK	92822	11/21/23	05/24	J & C ENTERPRISES			95.68				
AP CHK	92823	11/21/23	05/24	KIESLER POLICE SUPPLY			146.37				
AP CHK	92841	11/21/23	05/24	TASTE OF HOME BOOKS			38.98				
AP CHK	92843	11/21/23	05/24	TOM MCMANUS BACKHOE			500.00				
AP CHK	92846	11/22/23	05/24	LIFE INSURANCE			260.53				
AP CHK	92853	11/22/23	05/24	CENTURYLINK			149.92				
AP CHK	92858	11/22/23	05/24	MICHAEL YACKSHAW			206.97				
AP CHK	92862	11/22/23	05/24	REPUBLIC SERVICES			31,078.90				
AP CHK	92866	11/22/23	05/24	TUMBLEWEED PRESS INC.			499.00				
AP CHK	92868	11/22/23	05/24	WINDSTREAM			307.75				
UB CHK	92869	11/28/23	05/24	ADLER TAMMY			56.87				
UB CHK	92870	11/28/23	05/24	EBLE JEANNE			55.97				
UB CHK	92872	11/28/23	05/24	TOEPFER ANTHONY			71.65				
AP CHK	92876	11/30/23	05/24	ALLIANT ENERGY			1,035.27				
AP CHK	92877	11/30/23	05/24	BRITTNEY PARKS			76.98		12/05/2023		
AP CHK	92878	11/30/23	05/24	LIFE INSURANCE			978.44				
AP CHK	92879	11/30/23	05/24	MEDIACOM			450.00				
AP CHK	92880	11/30/23	05/24	PCC AMBULANCE BILLING SER			1,246.66				
AP CHK	92881	11/30/23	05/24	PREMIER PARTS INC			26.44				
AP ETR	10319744	11/22/23	05/24	IPERS			5,112.64			MANUAL	
AP ETR	10319747	11/22/23	05/24	AFLAC			465.00				
AP ETR	10319770	11/22/23	05/24	IPERS			3,289.66			MANUAL	
BANK TOTAL							972.77	83,468.88	.00		
DEPOSITS-CHECKS							82,496.11-				

BANK NO	DATE	JOURNAL	PENDING DEPOSITS	ADJUSTMENTS*
1	6/30/2022	RM 1589	159.64	.00
1	6/30/2022	RM 1611	159.64-	.00
1	7/06/2022	RM 1619	10,966.25	.00
1	7/06/2022	RM 1633	10,966.25-	.00
1	10/03/2022	RM 2012	164.89-	.00
1	11/01/2022	RM 2166	93.79	.00
1	11/01/2022	RM 2170	93.79-	.00
1	12/30/2022	RM 2377	207.76	.00
1	12/30/2022	RM 2398	207.76-	.00
1	1/12/2023	RM 2474	127.49	.00

## OUTSTANDING TRANSACTION REGISTER OPEN

MOD CODE	BANK NO	NAME	DATE	PERIOD	VEND/EMPL	OTHER NUMB	DEPOSITS	CHECKS AND WITHDRAWALS	RECONCILING	VOIDED	MANUAL
----------	---------	------	------	--------	-----------	------------	----------	---------------------------	-------------	--------	--------

BANK NO	DATE	JOURNAL	PENDING DEPOSITS	ADJUSTMENTS*
1	4/10/2023	RM 2846	963.17	.00
1	4/10/2023	RM 2849	963.17-	.00
1	10/02/2023	RM 3542	454.37	.00
1	10/02/2023	RM 3551	454.37-	.00
1	11/30/2023	RM 3796	50.00	.00
BANK TOTAL			12.60	.00
REPORT TOTAL			12.60	

\*Adjustments include fees and returns that reduce GWorks Payments Deposits.

**BANK CASH REPORT**  
2023

BANK NAME	OCTOBER	NOVEMBER	NOVEMBER	NOVEMBER	OUTSTANDING	NOV BANK
FUND GL NAME	CASH BALANCE	RECEIPTS	DISBURSMENTS	CASH BALANCE	TRANSACTIONS	BALANCE
CITIZEN'S FIRST BANK						
BANK CITIZEN'S FIRST BANK						3,640,725.56
001 CASH ON HAND-GENERAL	577,077.14	302,562.41	281,706.79	597,932.76		
001 CASH - INSURANCE FUND	69,148.58	479.69	522.59	69,105.68	43,735.24	
002 CASH-LIBRARY	42,787.84	31,104.74	17,059.04	56,833.54	2,003.64	
003 CASH-PARKS AND REC	29,579.59	9,406.87	4,990.95	33,995.51	491.98	
004 CASH-CEMETERY	4,711.88	8,810.61	6,865.07	6,657.42	691.36	
110 CASH-ROAD USE	277,972.99	53,627.14	51,223.91	280,376.22	1,868.70	
112 CASH - EMPLOYEE BENEFIT	136,836.82	12,624.86	8,982.73	140,478.95	990.06-	
117 CASH - CIVIL SVC. RET. EX	51,336.25	22,585.22	17,196.85	56,724.62		
125 CASH - TIF	50,793.52	0.00	0.00	50,793.52		
126 CASH-CROSS TIF-E RIVER CT	11,418.69	2,130.69	0.00	13,549.38		
145 CASH-LOW/MODERATE HOUSING	71,489.71	0.00	0.00	71,489.71		
146 CASH-CROSS LMI-E RIVER CT	32,067.63	1,305.91	0.00	33,373.54		
160 CASH - ECONOMIC DEVELOP.	0.00	0.00	0.00	0.00		
167 CASH - TRUST & AGENCY	0.00	0.00	0.00	0.00		
200 CASH-DEBT SERVICE	299,271.65	47,058.66	72,346.88	273,983.43		
301 CASH-STORM SEWER IMP PROJ	0.00	0.00	0.00	0.00		
303 ACC/GCC CASH	0.00	0.00	0.00	0.00		
304 CASH - MRT	0.00	0.00	0.00	0.00		
305 CASH-WASHINGTON BLVD.	0.00	0.00	0.00	0.00		
306 CASH - 9TH STREET BRIDGE	0.00	0.00	0.00	0.00		
307 CASH-9TH ST REC TRAIL	0.00	0.00	0.00	0.00		
308 CASH-EMERGENCY GENERATOR	0.00	0.00	0.00	0.00		
309 CASH-9TH AVE CURB & RECONST	0.00	0.00	0.00	0.00		
310 CASH-3RD ST MILL & OVERLAY	0.00	0.00	0.00	0.00		
311 CASH-21ST CULVERT	0.00	0.00	0.00	0.00		
312 CASH - 9TH AV/ANAMOSA/21ST ST	6,174.35	0.00	0.00	6,174.35		
313 CASH - WASH BLVD ENHANCEMENT	0.00	0.00	0.00	0.00		
314 CASH-CITY HALL PROJECT	0.00	0.00	0.00	0.00		
315 CASH-CITY HALL EXPANSION PROJ	0.00	0.00	0.00	0.00		
316 CASH-21ST ST CULVERT	0.00	0.00	0.00	0.00		
317 CASH	0.00	0.00	0.00	0.00		
318 CASH-AMERICAN RESCUE PLAN	128,323.60	0.00	0.00	128,323.60		
319 CASH PHASE III SIP/EQUIPMENT	0.00	0.00	0.00	0.00		
320 CASH-ROUNDAABOUT PROJECT	35,929.83-	0.00	0.00	35,929.83-		
321 CASH-9TH STREET PROJECT	330,603.87	0.00	30,195.87	300,408.00		
325 CASH-ACC/GCC WATER LINE EXTENS	119,125.00	0.00	2,175.00	116,950.00		
333 CASH-PFAS-3M	524,796.57	820.70	53,647.71	471,969.56	377.69	
334 CASH-TRAIN DEPOT PROJECT	23,350.00	0.00	14,500.00	8,850.00		
600 CASH-WATER	589,952.31	7,805.21	35,202.99	562,554.53		
600 WATER DEPOSITS	193,828.18	450.00	211.57	194,066.61	2,804.33	
610 CASH-SEWER	140,131.17	10,152.32	38,562.81	111,720.68	1,222.46	
615 CASH-SEWER SINKING FUND	0.00	0.00	0.00	0.00		
620 CASH-SEWER RESERVE	0.00	0.00	0.00	0.00		
670 CASH-GARBAGE	68,486.05	3,385.58	63,973.96	7,897.67	31,263.54	
PENDING CREDIT-CARD DEPOSITS					50.00	
DEPOSITS					972.77	
CITIZEN'S FIRST BANK TOTALS	3,743,333.56	514,310.61	699,364.72	3,558,279.45	82,446.11	3,640,725.56



# BANK CASH REPORT 2023

BANK NAME	OCTOBER	NOVEMBER	NOVEMBER	NOVEMBER	OUTSTANDING	NOV BANK
FUND GL NAME	CASH BALANCE	RECEIPTS	DISBURSMENTS	CASH BALANCE	TRANSACTIONS	BALANCE
TOTAL OF ALL BANKS	3,743,333.56	514,310.61	699,364.72	3,558,279.45	82,446.11	3,640,725.56

**TREASURER'S REPORT**  
**CALENDAR 11/2023, FISCAL 5/2024**

ACCOUNT TITLE	LAST MONTH END BALANCE	RECEIVED	DISBURSED	CHANGE IN LIABILITY	ENDING BALANCE
001 GENERAL	1,267,548.72	263,123.48	242,970.45	659.69	1,288,361.44
002 LIBRARY	84,569.28	28,051.21	13,963.91	.00	98,656.58
003 PARKS	88,815.82	8,162.50	3,746.58	.00	93,231.74
004 CEMETERY	14,889.05	7,091.67	5,146.13	.00	16,834.59
110 ROAD USE	277,972.99	50,585.78	48,182.55	.00	280,376.22
112 EMPLOYEE BENEFIT	136,836.82	11,634.80	7,992.67	.00	140,478.95
117 POLICE & FIRE PENSION	51,336.25	22,585.22	17,196.85	.00	56,724.62
125 EDENS - TIF	50,793.52	.00	.00	.00	50,793.52
126 CROSS TIF	11,418.69	2,130.69	.00	.00	13,549.38
145 LOW/MODERATE HOUSING	71,489.71	.00	.00	.00	71,489.71
146 LOW/MODERATE HOUSING CR	32,067.63	1,305.91	.00	.00	33,373.54
160 ECONOMIC DEVELOPEMENT	.00	.00	.00	.00	.00
167 P.C. & R. HOWSON TRUST	86,479.10	3.59	.00	.00	86,482.69
200 DEBT SERVICE	299,271.65	47,058.66	72,346.88	.00	273,983.43
302 CDBG	.00	.00	.00	.00	.00
312 9TH AV/ANAMOSA/21ST ST	6,174.35	.00	.00	.00	6,174.35
315 CITY HALL EXPANSION PRO	.00	.00	.00	.00	.00
316 21ST STREET CULVERT	.00	.00	.00	.00	.00
317 LANHART PROPERTY	.00	.00	.00	.00	.00
318 ARP-AMERICAN RESCUE PLA	128,323.60	.00	.00	.00	128,323.60
319 PHASE III SIP/EQUIPMENT	.00	.00	.00	.00	.00
320 ROUNDABOUT-7TH AVE/HWY	35,929.83-	.00	.00	.00	35,929.83-
321 9TH STREET PROJECT	330,603.87	.00	30,195.87	.00	300,408.00
325 ACC/GCC WATER LINE EXTE	119,125.00	.00	2,175.00	.00	116,950.00
333 PFAS	524,796.57	.00	52,827.01	.00	471,969.56
334 TRAIN DEPOT PROJECT	23,350.00	.00	14,500.00	.00	8,850.00
600 WATER UTILITY FUND	993,213.99	4,594.40	29,101.82	2,651.93-	966,054.64
610 SEWER UTILITY FUND	140,131.17	8,643.74	36,803.24	250.99-	111,720.68
670 LANDFILL/GARBAGE	68,486.05	2,950.56	63,538.94	.00	7,897.67
Report Total	4,771,764.00	457,922.21	640,687.90	2,243.23-	4,586,755.08



# State of Iowa

Alcoholic Beverages Division

## Applicant

NAME OF LEGAL ENTITY	NAME OF BUSINESS(DBA)	BUSINESS		
KWIK TRIP, INC.	Kwik Star #632	(563) 259-1651		
ADDRESS OF PREMISES	PREMISES SUITE/APT NUMBER	CITY	COUNTY	ZIP
803 7th Ave		Camanche	Clinton	52730
MAILING ADDRESS	CITY	STATE	ZIP	
1626 Oak Street	La Crosse	Wisconsin	54603	

## Contact Person

NAME	PHONE	EMAIL
Deanna Hafner	(608) 793-6262	dhafner@kwiktrip.com

## License Information

LICENSE NUMBER	LICENSE/PERMIT TYPE	TERM	STATUS
LG0000078	Class B Retail Alcohol License	12 Month	Submitted to Local Authority

EFFECTIVE DATE	EXPIRATION DATE	LAST DAY OF BUSINESS
Feb 8, 2024	Feb 7, 2025	

SUB-PERMITS

Class B Retail Alcohol License

PRIVILEGES



# State of Iowa

Alcoholic Beverages Division

## Status of Business

BUSINESS TYPE

Corporation

## Ownership

### • Individual Owners

NAME	CITY	STATE	ZIP	POSITION	% OF OWNERSHIP	U.S. CITIZEN
deanna hafner						
Thomas Reinhart	Onalaska	Wisconsin	54650	Secretary	0.00	Yes
Jeffrey Wrobel	La Crosse	Wisconsin	54601	Treasurer	0.00	Yes
Scott Zietlow	Rochester	Minnesota	55902	Owner	100.00	Yes
Maranda Oliver						

## Insurance Company Information

INSURANCE COMPANY

POLICY EFFECTIVE DATE

POLICY EXPIRATION DATE

DRAM CANCEL DATE

OUTDOOR SERVICE EFFECTIVE  
DATE

OUTDOOR SERVICE EXPIRATION  
DATE

BOND EFFECTIVE DATE

TEMP TRANSFER EFFECTIVE  
DATE

TEMP TRANSFER EXPIRATION  
DATE

December 7, 2023

City of Camanche Mayor Austin Pruett

City Council of Camanche

818 7<sup>th</sup> Ave

Camanche IA 52730

RE: My Appointment to the Board of Trustees for the Camanche Library

Dear Mayor and City Council Members,

Thank you for the opportunity to serve the citizens of Camanche as a trustee for the Camanche Library. I have loved the library since I was a young child residing in Camanche. I will continue to utilize the library, but can not continue on the board as a trustee at this time. Therefore, I am providing this letter as my official resignation from the board. I appreciate the opportunity.

Sincerely,

Janeen Reuter

Cc: Librarian Anna Evans

Trustee Jim Griswold

Trustee Shannon McManus

Trustee Linda Foster

Trustee Bill Goble

December 6th, 2023

The December meeting of the Board of Trustees of the Camanche Public Library was called to order by President Shannon McManus. Roll call was held and members present were McManus, Goble, Griswold, Foster, and Reuter, along with Librarian Evans, City Council liaison Dave Bowman, Becky Heil from the State Library of Iowa, and a public member.

A motion to approve the agenda was made by Trustee Foster and a second was made by Trustee Goble. All trustees aye. A motion to approve the minutes from the November 2023 meeting was made by Trustee Griswold and a second was made by Trustee Foster. All trustees were aye. A motion to approve the financials for November 2023 was made by Trustee Foster and a second was made by Trustee Goble. Discussion was held regarding line items for Code 6310 Repairs & Improvements \$12,860.00 and Code 6315 Property Insurance \$2860. Trustee Griswold would like to approve the financials except for these two items. He feels these two issues need further discussion. City Council liaison Bowman said the Repairs & Improvement bill was too high and the library bill will be \$11,000 instead of \$12,860 and the property insurance is a fixed cost with the city paying the insurance by placing money in the library's budget for it. The motion to approve financials failed. Trustee Griswold made a motion to approve November 2023 financials with the exception of the two items (Code 6310 Repairs & Improvements \$12,860.00 and Code 6315 Property Insurance \$2860) and a second was made by Trustee Foster. All trustees ay. Trustee Foster made a motion to approve the claims of \$6335.05 (bills/book orders) with Trustee Griswold seconding the motion. All trustees aye.

Book orders in the amount of \$1061.57 were approved to order from Ingram.

New Bills for December 2023 approved for payment:

- Amazon \$810.47
- MicroMarketing (books/audio/DVD) \$267.95
- CenterPoint \$272.02
- PlayAway \$434.98
- MidAmerica \$218.57
- Alliant \$223.14
- Culligan \$10.00
- PrestoX \$41.58
- Sparklean \$125.00
- Penworthy (Children's) \$540.93 (\$200 from Enrich Iowa)
- Penworthy (Adult Cognitive kits) \$329.90 (\$100 Direct State Aid)
- ProQuest (HeritageQuest) \$997.56
- Coast to Coast (Coloring books for Summer Reading Program) \$207.08 (\$200 Direct State Aid)
- Libby (Direct State Aid) \$137.00
- OverDrive (Advantage account) \$139.99
- OverDrive (Advantage account) \$387.71
- Air Control (repair of heating/cooling unit) \$746.60

Total of bills including Ingram: \$6942.05

Paid by Enrich Iowa: \$200.00

Paid by Direct State Aid: \$417.00

Total: \$6325.05

Becky Heil from the State Library of Iowa provided a Trustee Orientation presentation. Trustee Goble left at 5 pm.

#### Director's Report:

Financial: The items listed on the agenda under this item were discussed during financials listed above.

Personnel/Operational: Librarian Evans stated Shania will be going on leave due to medical reasons and would like to hire another employee to cover her leave. Trustee Griswold made a motion to hire another employee at 25 hours a week and Trustee Foster seconded it. All trustees aye.

Programming: no report given

Collection Development: no report given

Facilities: no report given

Summer Reading Program: no report given

Miscellaneous: no report given

Old Business: Librarian Evans stated she has been attempting to schedule a meeting with the City clerk and city administrator, but has not been successful. She stated she has emails if the trustees would like to look at them. Librarian Evans reported she is now being instructed to meet with all city hall staff and the meeting is to be held at city hall. Librarian Evans reported this is difficult due to having two new staff and one staff getting ready to go on medical leave and she would like Librarian Nancy to go with her. Discussion was held regarding this and how to resolve the matter. Trustee Reuter recommended going to city hall when they opened to discuss this as this meeting was to be scheduled from June 2023. Librarian Evans stated they would not meet with her then as she did not have a meeting. Trustee McManus inquired if City Council Liaison Bowman would assist in resolving this matter and report back to the board. He stated he would

City Council Liaison Bowman inquired why the board was looking at a contract for the library director. Trustee Reuter stated she thought it was to make the library director the same as other city department head. Librarian Evans reported she did not want a contract. Trustee Griswold stated he would meet with Trustee Reuter to review the contract and the matter was tabled until January meeting.

Librarian Evans inquired if Kanopy could be added to the library database. Trustee Griswold made a motion to include it in the 2024 – 2025 budget and a second was made by Trustee Foster. All trustees aye.

The budget for FY 2024 – 2025 was tabled until next meeting.

#### New Business:

Librarian Evans stated she would like to have mediation or something with Trustee Reuter as she feels yelled at during the meeting tonight and is being informed Trustee Reuter is talking about her in the community. She stated she could not have Trustees talking about her in the community. Trustee Reuter

stated she was resigning effective tonight. Librarian Evans instructed Trustee Reuter to notify the city council.

Liaisons Report:

City Council Liaison Bowman strongly urged the board to focus on FY 2024 – 2025 budget next meeting.

There were no public comments. President McManus adjourned the meeting.

The next meeting of the Camanche Public Library Board of Trustees will be held on January 3rd, 2024 at 4:00 pm at the Camanche Public Library

Respectfully submitted,  
Janeen Reuter, secretary



## Park and Rec Minutes

The meeting was called to order at 6:00p.m. on 12/11/23.

Linda Putman, Casey Green, Tony Blomme and Marty Schnoor were present.

A motion was made to Approve November 27th minutes. 1<sup>st</sup> Tony Blomme, 2<sup>nd</sup> Linda Putman. All in favor so motion carried.

A motion was made to approve the financials. 1<sup>st</sup> Linda Putman 2<sup>nd</sup> Tony Blomme. All in favor so motion carried.

There was a discussion on the Splash pad. We are waiting to hear back from Dan at Shive. Water Odyssey sent Casey information on 22 grants available. Casey will start working on the ones he thinks we qualify for.

There was a discussion on the Anthony Park completion. We need to reach out to River City Properties to see if they are going to complete it. We did get another bid and will get more if we need to get someone else to complete it.

A motion was made to disperse funds to the Holiday House. 1<sup>st</sup> Tony Blomme and 2<sup>nd</sup> Linda Putman. All in favor so motion carried.

### New Business

Tony said the post on the dugouts at Peck Park are in need of repair or to be replaced. Casey will go check them out and see if it is something that Gaylon can fix.

The Board would like to thank Marty Schnoor for all his hard work and dedication to our community. Thank you, Marty!

Meeting Adjourned 6:40pm.

Respectfully submitted,

Linda Putman

**From: Dave Bowman**  
**To: City Council**  
**Subj: Library Board**

The following occurred at the December 6<sup>th</sup> Library Board Meeting:

1. The Board voted unanimously to not pay for insurance or the costs associated with the recent parking lot repair.
2. The newest Board member left at 1700 to attend to duties associated with his job at the Middle School. The visitor from the State Library was in the middle of her presentation on responsibilities of Library Board members (specifically scheduled for this new member) when this happened.
3. One of the Trustees resigned from the Board. This happened during a heated discussion regarding the timesheets. This discussion, which was between the Trustee in question and the Library Director, occurred after the visitor from the State Library, the newest Board member and a member of the public who was present at the start of the meeting had left.
4. No progress was made on the Library budget for FYE25. This item was on the agenda.

At the December 19<sup>th</sup> Council meeting I will be requesting a formal agenda item during a future meeting to discuss the Library Board.



818 7<sup>th</sup> Ave PO Box 77  
Camanche, Iowa 52730  
563-259-8342 [www.camancheia.org](http://www.camancheia.org)

## Payment to RJ Edens Rental Property December 2023

4<sup>th</sup> Addition \$ 19,874.74 125-520-6420

9<sup>th</sup> to 9<sup>th</sup> Street \$ 28,599.86 125-520-6419

3<sup>rd</sup> Street 100% \$ 5,455.53 125-520-6418

\$ 53,930.13



818 7<sup>th</sup> Ave PO Box 77  
Camanche, Iowa 52730  
563-259-8342 [www.camancheia.org](http://www.camancheia.org)

**December 2023**

**Payment to Cross Roads Land Development, L.L.C.**

East River Court                      \$ 13,959.88 126-520-6419

**28E AGREEMENT CONCERNING COLLABORATIVE LOBBYING EFFORT BY AND  
BETWEEN GOVERNMENTAL ENTITIES AND COOPERATING ENTITIES IN  
CLINTON COUNTY, IOWA**

This intergovernmental Agreement (“Agreement”) under Iowa Code Chapter 28E is made between the following political subdivisions of the State of Iowa: Clinton County (“the County”); the City of Clinton (“Clinton”); the City of Camanche (“Camanche”); the City of DeWitt (“DeWitt”); as well as Grow Clinton (“Grow”) (collectively, “the parties”).

**I. RECITALS**

Whereas, the need exists to provide for lobbying efforts on behalf of all the aforementioned entities on legislative matters pending before the Iowa legislature; and

Whereas, the parties share certain common goals and wish to collaborate to the mutual benefit of all the parties; and

Whereas, the parties desire to pool their resources to hire a lobbyist to work on their joint behalf;

The parties therefore agree:

**II. PURPOSE AND SCOPE**

This Agreement establishes joint governance and equitable financing of a joint lobbying effort, and to that end, the hiring of a lobbying firm, Eide & Heisinger, LLC, d/b/a Eide • Walton 6550 Aspen Dr, West Des Moines, IA 50266 (“the Lobbyist”), for the 2024 Calendar Year. The terms of which are memorialized in Exhibit A to this agreement.

**III. STATUTORY AUTHORITY/GOVERNING LAW**

This agreement shall be governed by, construed and enforced under the laws of Iowa; this Agreement is made under statutory authority granted to the parties under Iowa Code Section 28E.4 and other relevant Iowa law.

**IV. DURATION**

This Agreement shall take effect upon the approval by the respective city councils and governing boards of each party to this agreement and shall continue for one year thereafter, unless renewed by the terms of this agreement and by a successor agreement to Exhibit A. This Agreement may be renewed or extended for such period as agreed upon by the parties.

**V. CREATION OF CLINTON COUNTY ADVOCACY CONTROL BOARD**

By this Agreement, the parties create the Clinton County Advocacy Control Board (“CCA Control Board”).

1. CCA Control Board

All other authority to direct lobbying efforts of the Lobbyist shall be vested in the voting members of the CCA Control Board. The voting members shall be comprised of an appointed

representative of each of the six parties who are the signatories to this Agreement. Directors shall be appointed by the respective political authorities of each signatory, and shall be distributed based roughly upon those entities' financial contribution set forth *infra*. Representation shall be:

- a. City of Clinton: Representative has 2 votes;
- b. Clinton County: Representative has 2 votes;
- c. City of Camanche: Representative has 1 vote;
- d. City of DeWitt: Representative has 1 vote;
- e. Grow Clinton: Representative has 2 votes;

Each party shall have the authority to designate one voting representatives at its discretion, but each voting member shall be a duly elected Mayor, Supervisor, or employee of the appointing party.

Each voting member, once duly appointed by the signatory, shall have the authority to send a proxy to any meeting, and who shall have the same authority as the member, provided that the proxy must also be a duly elected public official or employee of the appointing party.

The Chairmanship of the CCA Control Board shall rotate annually, with the first Chair person being the member from the City of Clinton. The Chair shall make an extra tie-breaking vote on any tie votes.

## 2. Duties of CCA Control Board

The CCA Control Board shall meet as soon as practicable following approval of the Agreement, and thereafter at least every ninety (90) days during the legislative session to pass, by majority vote a resolution approving a written memorandum setting forth the lobbying priorities to be provided to the Lobbyist. Meetings may be set more often by the Chair, if the chair believes legislative priorities should be re-examined, or if major legislative changes occur, or if the Lobbyist so recommends. In the event the majority of the Board determines not to change legislative priorities at any given meeting, the resolution set at the previous meeting shall stand and no new resolution need be passed. The Chair shall appoint a member of the Board to act as secretary to keep minutes of the meetings and to ensure the appropriate memorandum is prepared and transmitted to the Lobbyist.

## **VI. NON-INCORPORATION/ADDRESS/LEGAL POWERS OF CCA CONTROL BOARD**

Due to the lack of any funds to be held by the CCA Control Board (the payment of funds shall be made directly to Lobbyist by the participating entities) and the lack of any other incentives weighing in favor of incorporation, the CCA Control Board shall not be incorporated by the laws of Iowa, but rather shall be considered a joint board under 28E.6(1)(a) of the Iowa Code. The official address of CCA Control Board shall be:

Clinton County Advocacy Control Board  
c/o Mayor, City of Clinton  
611 S. 3<sup>rd</sup> St.  
PO Box 2958  
Clinton, IA 52733-2958

The Board shall hold no real or personal property or funds.

**VII. COST SHARING**

For the 2024 year, the contribution to the cost of Exhibit A shall be:

Entity	Contribution
Clinton	\$7400
Clinton County	\$7400
Camanche	\$1300
DeWitt	\$1300
Grow Clinton	\$2600

**VIII. MEETINGS/RECORDS**

CCA Control Board’s meetings shall be conducted in compliance with Chapters 21, 22 and 28E of the Code of Iowa as amended.

**IX. TERMINATION/AMENDMENTS/CONTINUATION**

Termination of this Agreement shall automatically occur one year following its inception, unless this Agreement is affirmatively extended by unanimous vote of all parties. Amendments or modifications to this Agreement may be made from time to time, by unanimous approval of all parties, in writing. Any such amendments, modifications, or notice of termination must be in writing, approved by all parties to this Agreement, and filed with the Secretary of State in conformance with Section 28E.8 (1) (b) of the Code of Iowa.

**X. INTERPRETATION AND ENFORCEMENT**

Interpretation and enforcement of this Agreement shall be under Chapter 28E of the Code of Iowa, as amended, and statutes respecting the rights and responsibilities of political subdivisions.

**XI. SEVERABILITY**

If a provision of this Agreement shall be finally declared void or illegal by any court or administrative agency having jurisdiction over the parties to this Agreement, the entire Agreement shall not be void, but the remaining provisions shall continue in effect as nearly as possible in accordance with the original intent of the parties.

**XII. ENTIRE AGREEMENT**

This Agreement sets forth all of the covenants, promises, agreements and conditions among the parties. There are no other covenants, promises, agreements or conditions either oral or written or binding and effective.

**XIII. SIGNATURES**

Each of the undersigned declares and certifies they had been authorized by Clinton, Clinton County, Camanche, DeWitt, and Grow Clinton to execute this Agreement on behalf of the parties to this Agreement, that prior to the execution of this Agreement the City of Clinton by and through its City Council, Clinton County, by and through its Board of Supervisors, the City of Camanche by and through its City Council; the City of DeWitt by and through its City Council, and Grow Clinton, by and through its Board, have passed resolutions approving this Agreement and authorizing the persons executing this agreement below to sign same, and that upon execution of this Agreement shall become effective and binding upon Clinton, Clinton County, Camanche, DeWitt, and Grow Clinton.

City of Clinton, Iowa

Attest:

By \_\_\_\_\_  
Mayor

\_\_\_\_\_  
City Clerk

Clinton County, Iowa

Attest:

By \_\_\_\_\_  
Chairman, Board of Supervisors

\_\_\_\_\_  
Auditor

City of Camanche, Iowa

Attest:

By \_\_\_\_\_  
Mayor

\_\_\_\_\_  
City Clerk

City of DeWitt, Iowa

Attest:

By \_\_\_\_\_  
Mayor

\_\_\_\_\_  
City Clerk

Grow Clinton

Attest:

By \_\_\_\_\_  
Authorized Representative

\_\_\_\_\_



12.19.2023

# City of Camanche

# Agenda

1. Final Scope Breakdown
2. Final Scope Descriptions
3. Cost and Savings
4. ABM Financing and Funding
5. Questions and Discussion
6. Next Steps

# Final Scope Breakdown

Water Meter Infrastructure	70%
Ground Mount/Rooftop Solar	24%
HVAC/Lighting	6%

Solution Breakdown

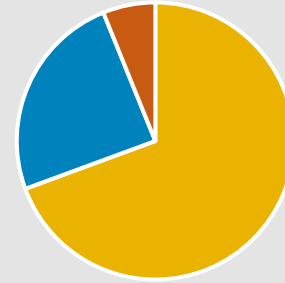

■ Water Meter ■ Solar ■ HVAC/Lighting

# Solar Installation

## Technical Solution and Benefits

- TC-11.1: Solar
  - Provide up to 100% capacity solar generated power
  - Complete structural ballasted ground mount design and engineering
- Locations:
  - Camanche Fire Station
  - Public Works Building
  - Well #5
  - Tower 1
  - Hwy 67 Tower
  - New Well Location



# HVAC Replacement

## Technical Solution and Benefits

- TC: 4.1: HVAC Upgrades
  - Furnace Replacement
  - Install Bipolar ionization for clean air
- Locations:
  - Public Works
  - Police Station
  - Historical Society (Return Air)
  - Library (Dehumidification System)



# Lighting Upgrade

## Technical Solution and Benefits

- TC-5.1: LED Lighting
  - Complete the LED Retrofit
- Locations:
  - Historical Society
  - Public Works Building
  - Library



# Water Meters and Cellular Read System

## Technical Solution and Benefits

- TC-13.0: Water Meter Replacement

5/8" X 3/4"	Badger M25 PD Meter
Short 3/4"	Badger M35 PD Meter
1"	Badger M70 PD Meter
1.5"	Badger E-Series Meter
2"	Badger E-Series Meter
4"	Badger E-Series Meter

- TC-13.1: Water Meter Infrastructure and Billing

- Cellular AMI System
- Integration of Badger Beacon System with Simple City software
- Advanced technology provides for instantaneous readings
- Accuracy will help with any billing discrepancies / inquiries
- Identify Leaks/Pipe Breaks

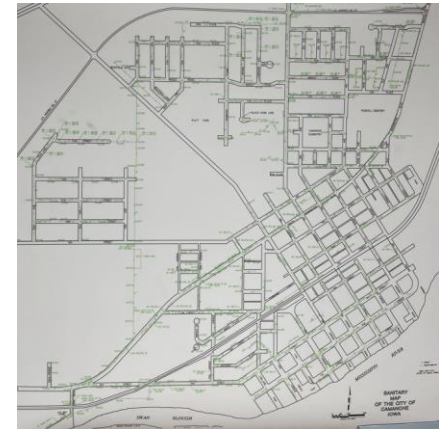
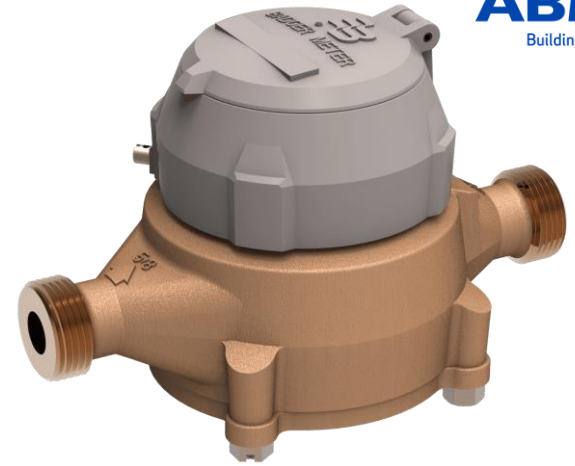

# AMI Smart System

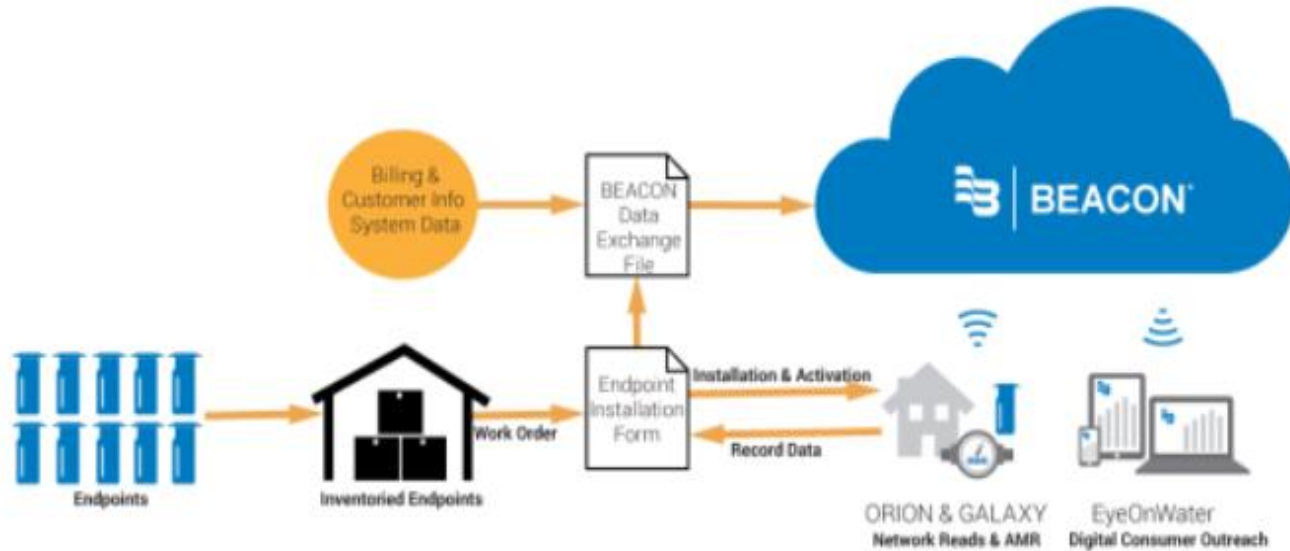



# Water Meter Testing Results

## AWWA Standard Tests

**Meter Size:** 0.625 (5/8")  
**Meter Type:** PD Displacement  
**Test Dates:** 10/31/2023  
**Water Utility:** CAMANCH E IA

**Weighted Factors:** Min. 15.0% Inter. 70.0% Max. 15.0%

Ref #	Manufacturer	Serial #	READING	Minimum Flow		Intermediate Flow		High Flow		Weighted Average Accuracy (%)
				Rate (gpm)	Accuracy (%)	Rate (gpm)	Accuracy (%)	Rate (gpm)	Accuracy (%)	
1	HERSEY	11470235	428,910	0.25	100.0%	2.00	96.0%	15.00	99.0%	97.1%
2	HERSEY	11474545	704,130	0.25	93.0%	2.00	94.0%	15.00	98.0%	94.5%
3	HERSEY	11474488	59,920	0.25	100.0%	2.00	100.0%	15.00	98.0%	99.7%
4	HERSEY	11470318	351,870	0.25	98.0%	2.00	100.0%	15.00	97.0%	99.3%
5	HERSEY	11470208	839,660	0.25	86.0%	2.00	94.0%	15.00	97.0%	93.3%
6	HERSEY	11533344	513,130	0.25	100.0%	2.00	100.0%	15.00	100.0%	100.0%
7	HERSEY	11470332	581,920	0.25	12.0%	2.00	96.0%	15.00	98.0%	83.7%
8	HERSEY	11470274	369,260	0.25	88.0%	2.00	96.0%	15.00	98.0%	95.1%
9	HERSEY	11474649	564,560	0.25	96.0%	2.00	100.0%	15.00	98.0%	99.1%
10	HERSEY	11474647	409,160	0.25	96.0%	2.00	98.0%	15.00	98.0%	97.7%
11	HERSEY	11474614	709,880	0.25	96.0%	2.00	96.0%	15.00	97.0%	96.2%
12	HERSEY	11533413	363,580	0.25	100.0%	2.00	100.0%	15.00	100.0%	100.0%
13	HERSEY	11470305	497,550	0.25	0.0%	2.00	92.0%	15.00	95.0%	78.7%
14	HERSEY	11474930	169,810	0.25	78.0%	2.00	92.0%	15.00	96.0%	90.5%
15	HERSEY	11470392	338,620	0.25	100.0%	2.00	100.0%	15.00	100.0%	100.0%
16	HERSEY	11470255	1,164,130	0.25	98.0%	2.00	98.0%	15.00	97.0%	97.9%

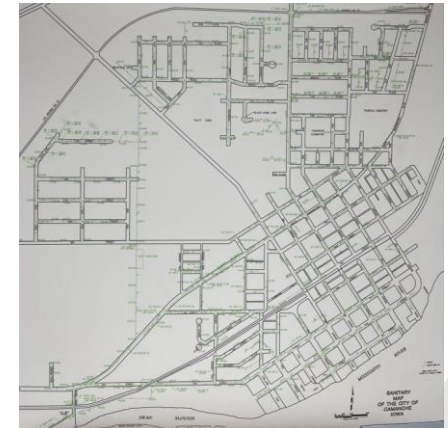

# Water Meter Testing Summary

## 35 total meters pulled and tested

- 16 - 1/2" Meters
  - 1200 of 1700 meters in population
- 14 - 3/4" Meters
- 1 - 1" Meter
- 3 – 2" Meters

## ***Average accuracy rating from 78.7% to 100%***

- 70% of population of meters tested at an average of 93%
- Last water meter read showed 44 new meters not communicating

Project Cost: \$3,696,189

- Guaranteed Maximum Price
- Full Turnkey Solution
- No Change Orders

Project Savings (20 yrs.) : \$2,245,261

- HVAC and LED Upgrades: \$38,240
- Solar-PV Installation: \$707,021
- Water Meter Infrastructure Integration: \$1,500,000

Additional Grants/Rebates/Incentives

- Federal Solar Incentive: \$208,300

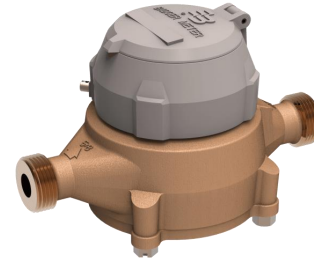

# ABM Funded Project

## Camanche - ABM Financing and Funding

Project Cost: \$3,696,189.00  
Term: 12 Years  
Contract Date: 2/1/2024 \*Estimated

### Payment

Number	Payment Date	Payment Amount	Savings	Net Annual Payment
1	2/1/2025	\$484,130.00	\$78,128.00	\$406,002.00
2	2/1/2026	\$484,130.00	\$81,181.00	\$402,949.00
3	2/1/2027	\$484,130.00	\$84,231.00	\$399,899.00
4	2/1/2028	\$484,130.00	\$87,462.00	\$396,668.00
5	2/1/2029	\$484,130.00	\$90,820.00	\$393,310.00
6	2/1/2030	\$484,130.00	\$94,310.00	\$389,820.00
7	2/1/2031	\$484,130.00	\$97,936.00	\$386,194.00
8	2/1/2032	\$484,130.00	\$101,704.00	\$382,426.00
9	2/1/2033	\$484,130.00	\$105,620.00	\$378,510.00
10	2/1/2034	\$484,130.00	\$109,690.00	\$374,440.00
11	2/1/2035	\$484,130.00	\$113,920.00	\$370,210.00
12	2/1/2036	\$484,130.00	\$118,315.00	\$365,815.00



# Thank You

**Dan Lawlor**  
[Dan.Lawlor@ABM.com](mailto:Dan.Lawlor@ABM.com)

**Dan Choi**  
[Dan.choi@abm.com](mailto:Dan.choi@abm.com)



Project Cost: \$3,696,189.00  
 Term: 12 Years  
 Contract Date: 2/1/2024 \*Estimated

Payment				
Number	Payment Date	Payment Amount	Savings	Net Annual Payment
1	2/1/2025	\$484,130.00	\$78,128.00	\$406,002.00
2	2/1/2026	\$484,130.00	\$81,181.00	\$402,949.00
3	2/1/2027	\$484,130.00	\$84,231.00	\$399,899.00
4	2/1/2028	\$484,130.00	\$87,462.00	\$396,668.00
5	2/1/2029	\$484,130.00	\$90,820.00	\$393,310.00
6	2/1/2030	\$484,130.00	\$94,310.00	\$389,820.00
7	2/1/2031	\$484,130.00	\$97,936.00	\$386,194.00
8	2/1/2032	\$484,130.00	\$101,704.00	\$382,426.00
9	2/1/2033	\$484,130.00	\$105,620.00	\$378,510.00
10	2/1/2034	\$484,130.00	\$109,690.00	\$374,440.00
11	2/1/2035	\$484,130.00	\$113,920.00	\$370,210.00
12	2/1/2036	\$484,130.00	\$118,315.00	\$365,815.00

Water and Sewer 70%	Funding Buckets	
	Solar 24%	HVAC - Electric 6%
\$284,201.40	\$97,440.48	\$24,360.12
\$282,064.30	\$96,707.76	\$24,176.94
\$279,929.30	\$95,975.76	\$23,993.94
\$277,667.60	\$95,200.32	\$23,800.08
\$275,317.00	\$94,394.40	\$23,598.60
\$272,874.00	\$93,556.80	\$23,389.20
\$270,335.80	\$92,686.56	\$23,171.64
\$267,698.20	\$91,782.24	\$22,945.56
\$264,957.00	\$90,842.40	\$22,710.60
\$262,108.00	\$89,865.60	\$22,466.40
\$259,147.00	\$88,850.40	\$22,212.60
\$256,070.50	\$87,795.60	\$21,948.90

RESOLUTION NO. \_\_\_\_\_

**A RESOLUTION SETTING A PUBLIC HEARING FOR THE PROPOSED AMENDMENT TO ZONING ORDINANCE MAP OF THE CITY OF CAMANCHE, IOWA FOR THE PURPOSE OF REZONING CERTAIN LANDS FROM M-2/M-3 HEAVY INDUSTRIAL AND Ab AGRICULTURAL RURAL TO M-RE UTILITY SCALE OVERLAY**

WHEREAS, the City of Camanche Planning and Zoning Commission met on November 28, 2023 to review changes to Zoning Ordinance 18.60-G Special Ordinances: Non-Utility / Utility Scale Solar for the purpose of approving a Utility Scale Overlay for a proposed solar project; and

WHEREAS, the Camanche Planning and Zoning Commission voted unanimously to recommend approval of the application by Rock Creek Solar, LLC to change the zoning of certain lands currently designated as M-2/M-3 Heavy Industrial and Ab Agricultural Rural, and

WHEREAS, Camanche Zoning Ordinance 18.70.410 requires 15 day notice for the publication of a public hearing for the proposed changes to the Zoning District boundaries, and

WHEREAS, the City of Camanche is required to hold a public hearing in order to amend the Zoning Ordinance.

NOW, THEREFORE, BE IT RESOLVED by the City Council of the City of Camanche, Iowa that the matter amending Chapter 18.60-G Special Ordinances: Non-Utility / Utility Scale for the purpose of rezoning for a Utility Scale Renewable Overlay be set down for public hearing on January 16, 2024 at 6:00 p.m. in the Council Chambers at the Camanche City Hall, 818 7<sup>th</sup> Avenue, Camanche, Iowa.

BE IT FURTHER RESOLVED that the City Clerk is hereby authorized and directed to publish in an official newspaper, the notice of the time and place of said hearing at which time the City Council will hear from those parties, both for and against, interested in the adoption of the amendment to Zoning Ordinance 18.60-C Supplementary Sign Regulations.

Passed and Approved by the Council of the City of Camanche, Iowa this 19<sup>th</sup> day of December, 2023.

\_\_\_\_\_  
Austin Pruetz, Mayor

Attest: \_\_\_\_\_  
Toni L. Schneider, City Clerk



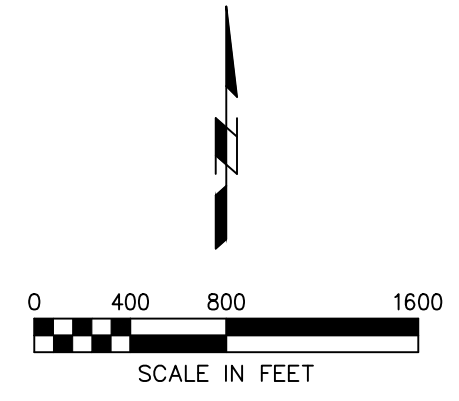
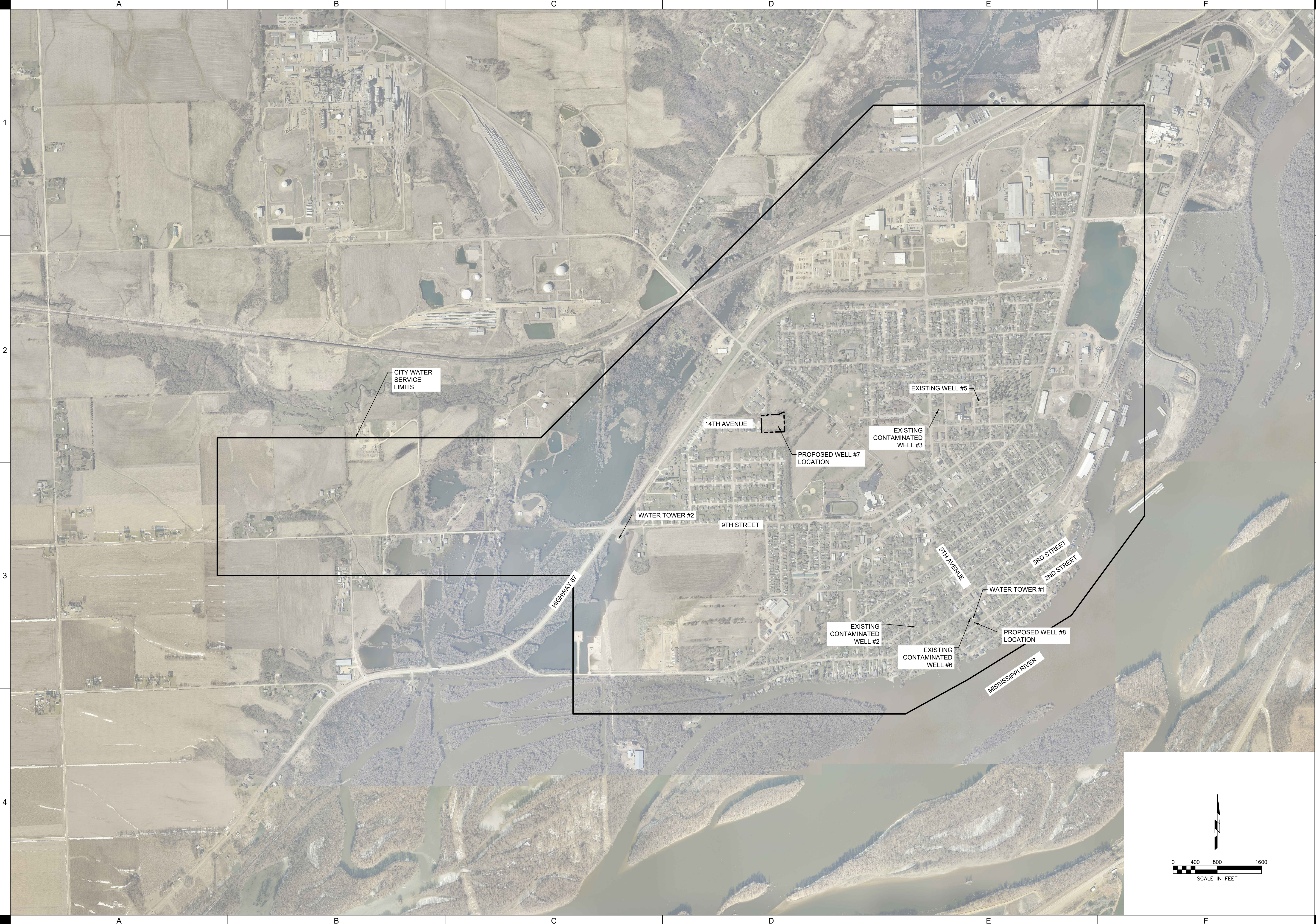

EXISTING FACILITIES

EX01

DRAWN BY	KCH
APPROVED BY	TLW
ISSUED FOR	REVIEW
ISSUE DATE	12/15/2023
PROJECT NUMBER	2132201064
FIELD BOOK	--

PRELIMINARY  
- NOT FOR  
CONSTRUCTION

3M DRINKING WATER  
COMPLIANCE

CITY OF CAMANCHE  
CLINTON COUNTY, IA

SHIVE-HATTERY  
ARCHITECTURE + ENGINEERING

2144 56TH AVENUE WEST  
BETTENDORF, IOWA 52722  
563.635.7300 | SHIVE-HATTERY.COM

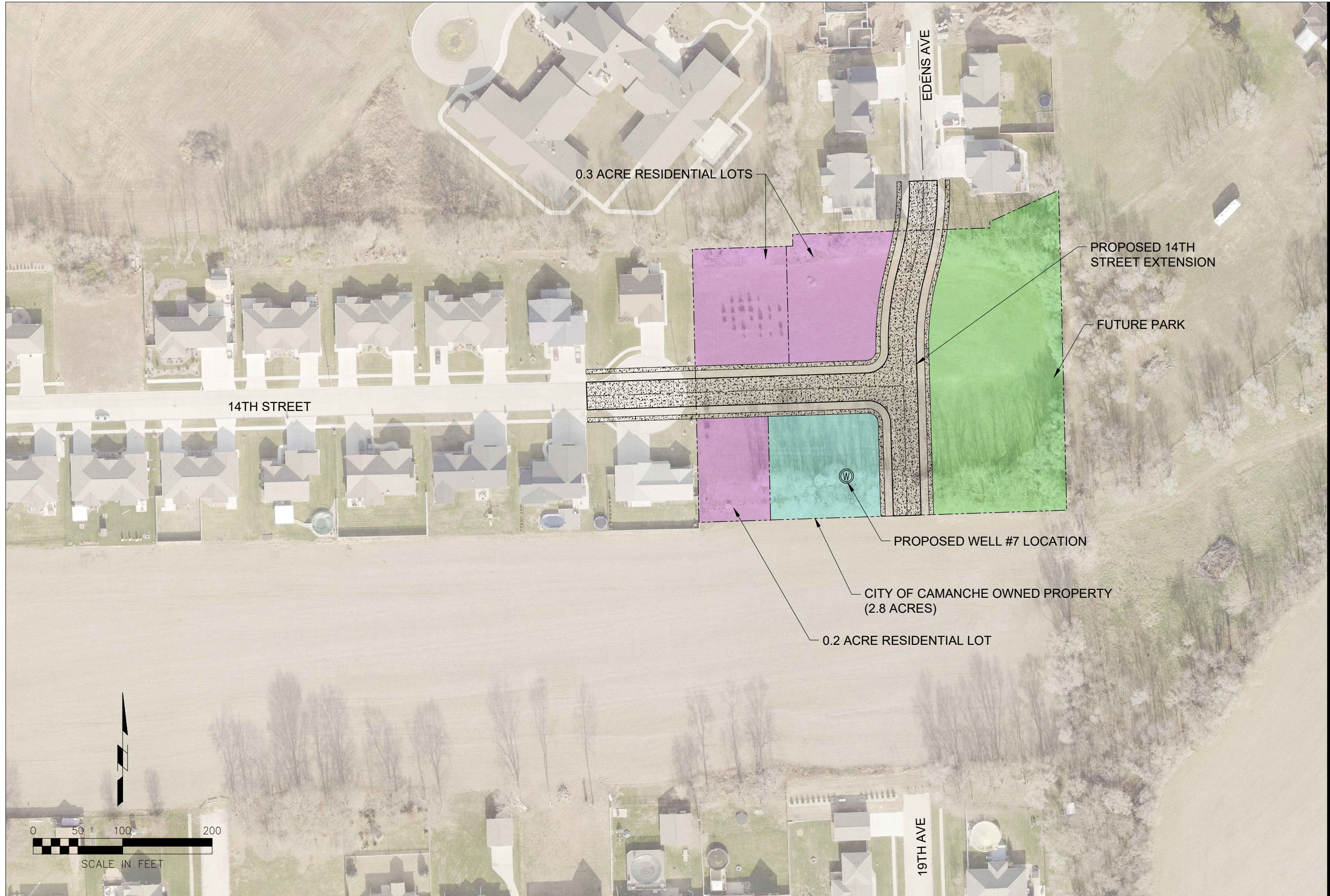

14TH STREET EXTENSION

CITY OF CAMANCHE

2132301050

FUTURE SITE PLAN

EX02

DATE	SCALE	FIELD BOOK
12/15/2023	---	---
DRAWN BY	REVISION	APPROVED BY
---	---	---

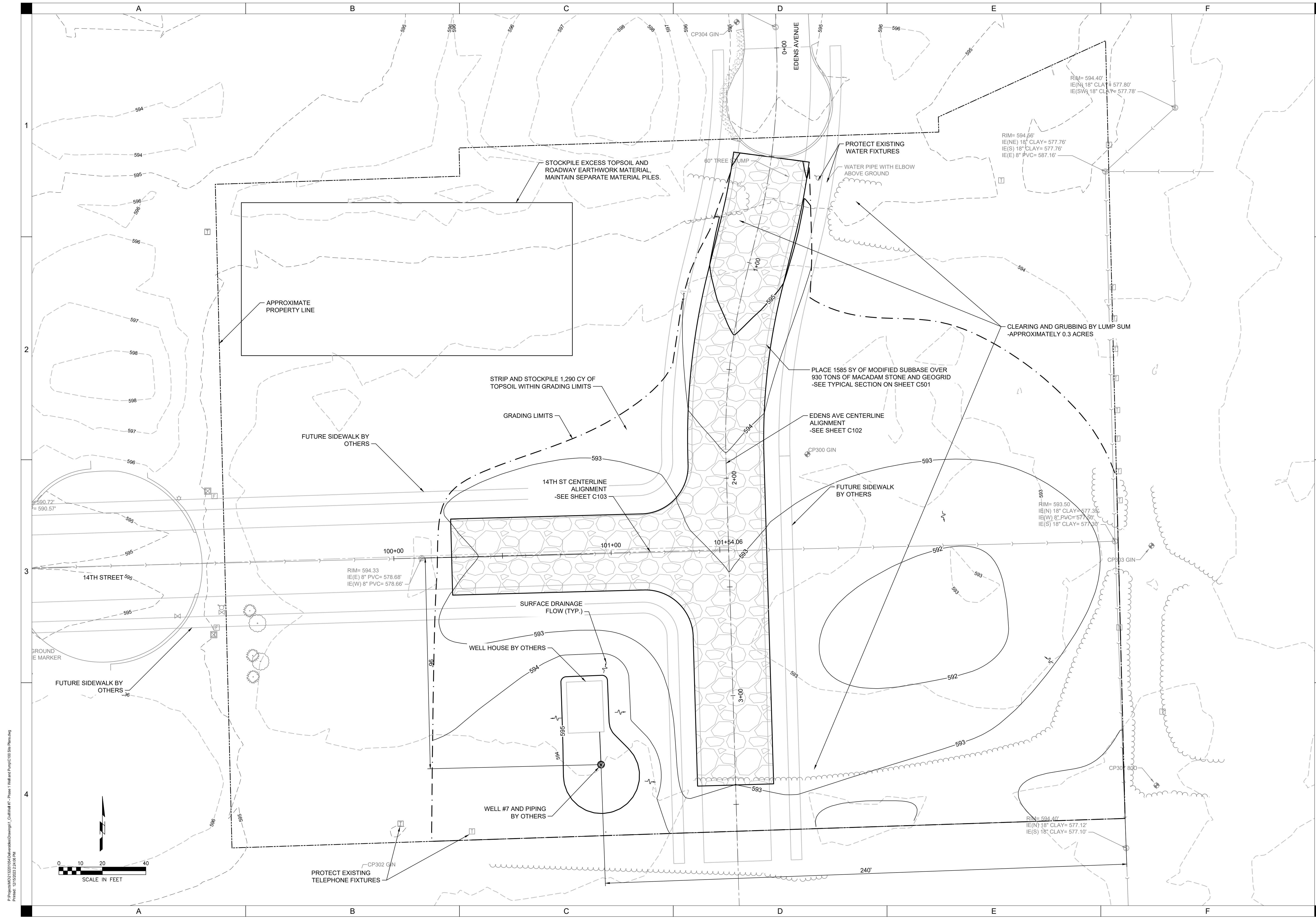

P:\Projects\2023\231056\Drawings\Well#7\_Phase\_1\Well#7\_Phase\_1\Well#7\_Phase\_1\Well#7\_Phase\_1.dwg  
 Printed: 12/15/2023 2:24:08 PM

**SHIVE-HATTERY**  
ARCHITECTURE + ENGINEERING

2144 56TH AVENUE WEST  
BETTENDORF, IOWA 52722  
563.635.7300 | SHIVE-HATTERY.COM

**WELL #7 PHASE 1**  
**CONSTRUCTION ACCESS**

CITY OF CAMANCHE  
CAMANCHE, IA

**OVERALL SITE PLAN**

**EX03**

DRAWN BY	KCH	DCS	BIDDING	12/15/2023	2142201064	1
APPROVED BY						
ISSUED FOR						
ISSUE DATE						
PROJECT NUMBER						
FIELD BOOK						

WELL #7 PHASE 2 - WELL AND PUMP

CITY OF CAMANCHE  
CAMANCHE, IA

DRAWN BY	KCH
APPROVED BY	TLW
ISSUED FOR	BIDDING
ISSUE DATE	12/20/2023
PROJECT NUMBER	2132201054
FIELD BOOK	1

WELL PROFILE

EX04

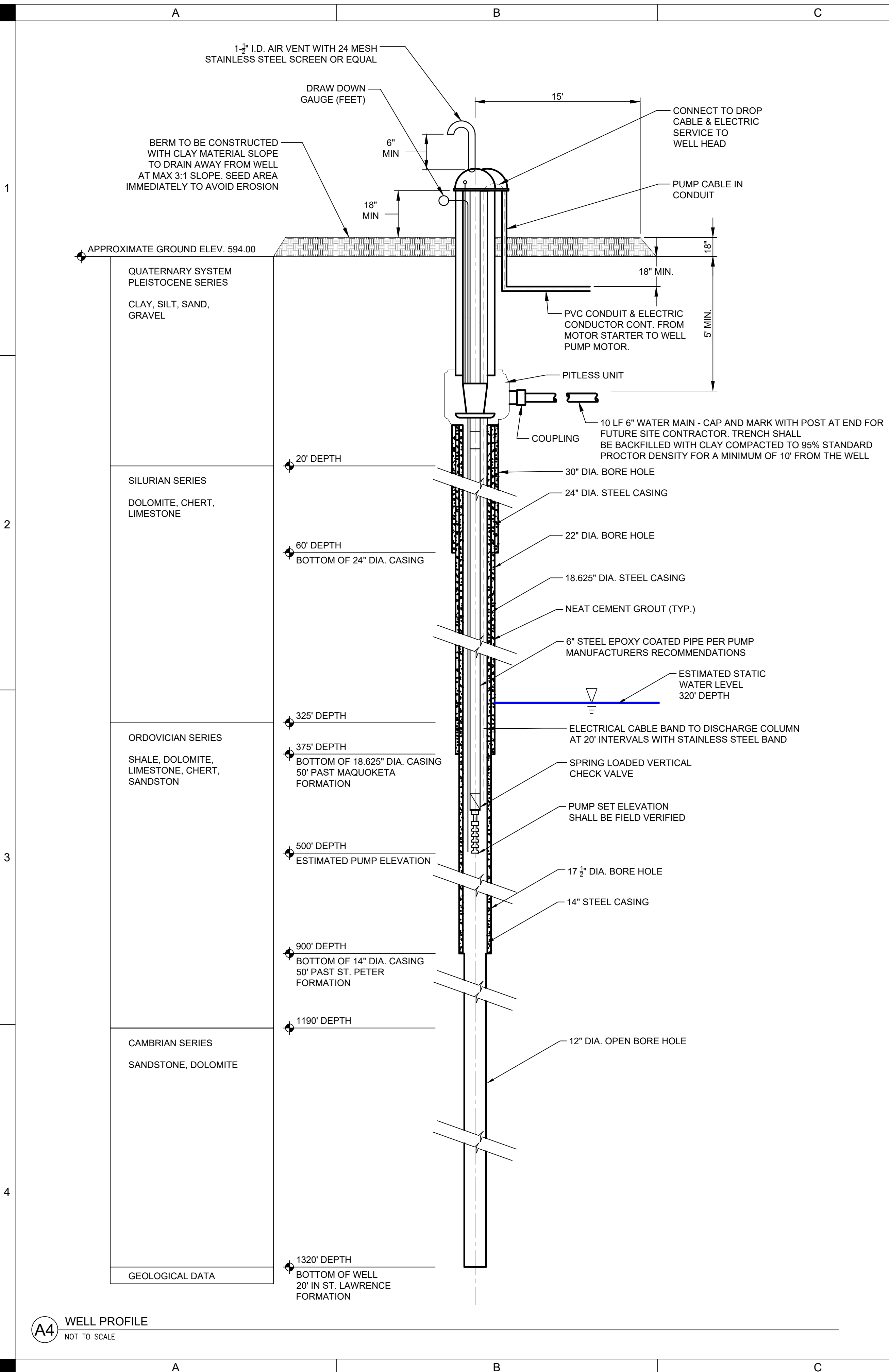

- NOTES:
1. WELL CONSTRUCTION IS TO BE IN ACCORDANCE WITH LOCAL STANDARDS, IDNR DESIGN STANDARDS, THE RECOMMENDED STANDARDS FOR WATER WORKS (TEN STATE STANDARDS) AND AWWA A 100.
  2. GEOLOGICAL SAMPLES AND WELL CONSTRUCTION LOGS ARE TO BE FORWARDED TO IOWA GEOLOGICAL SURVEY BUREAU AND THE IOWA DEPARTMENT OF NATURAL RESOURCES.
  3. ACIDIZE, TEST PUMP AND DEVELOP WELL TO DETERMINE THE SAFE YIELD CAPACITY. COLLECT WATER SAMPLE FOR TESTING AT COMPLETION OF TEST PUMPING.
  4. WELL SHALL BE DISINFECTED IN ACCORDANCE WITH AWWA C654.
  5. A BENTONITE SEAL SHALL BE PLACED FROM THE BOTTOM OF THE PITLESS UNIT UP TO THE BASE OF THE PITLESS ADAPTER AND WATER LINE.
  6. PROVIDE A 1/2" DIAMETER HEAVY PLASTIC AIR LINE IN THE WELL FOR WATER DEPTH MEASUREMENT. THE LINE SHALL EXTEND TO THE TOP OF THE PUMP BOWLS. THE AIR LINE SHALL BE STRAPPED TO THE COLUMN PIPE AT EACH JOINT WITH A STAINLESS STEEL BANDS. THE PORTION OF THE AIR LINE ABOVE THE DISCHARGE SHALL BE 1/2" COPPER PIPE FITTED WITH AN AIR VALVE. AIR LINE, DIRECT READING WATER DEPTH GAUGE CALIBRATED IN FEET, OF WATER, AND A SNUBBER VALVE WITH GAUGE. MEASURE AND RECORD THE FINAL DEPTH SETTING OF THE AIR LINE.
  7. DEPTH OF WELL CASINGS AND PUMP SET ELEVATION SHALL BE FIELD VERIFIED BASED ON CONDITIONS ENCOUNTERED DURING DRILLING.
  8. ALL STEEL CASINGS SHALL CONFORM TO AWWA STANDARD A-100.
  9. WATERMAIN SHALL BE PVC C900 IN ACCORDANCE WITH IOWA SUDAS 5010.

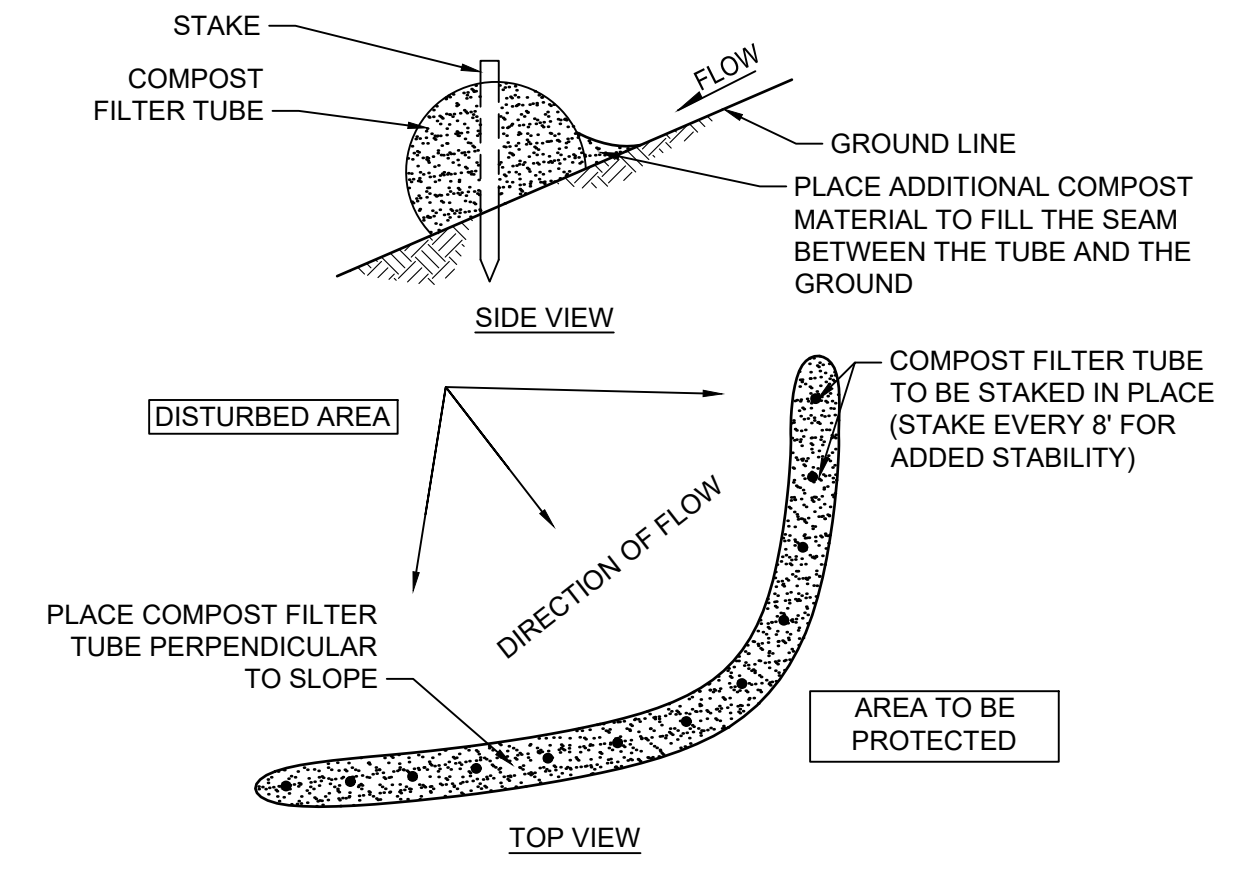

D3 COMPOST FILTER TUBE  
NOT TO SCALE

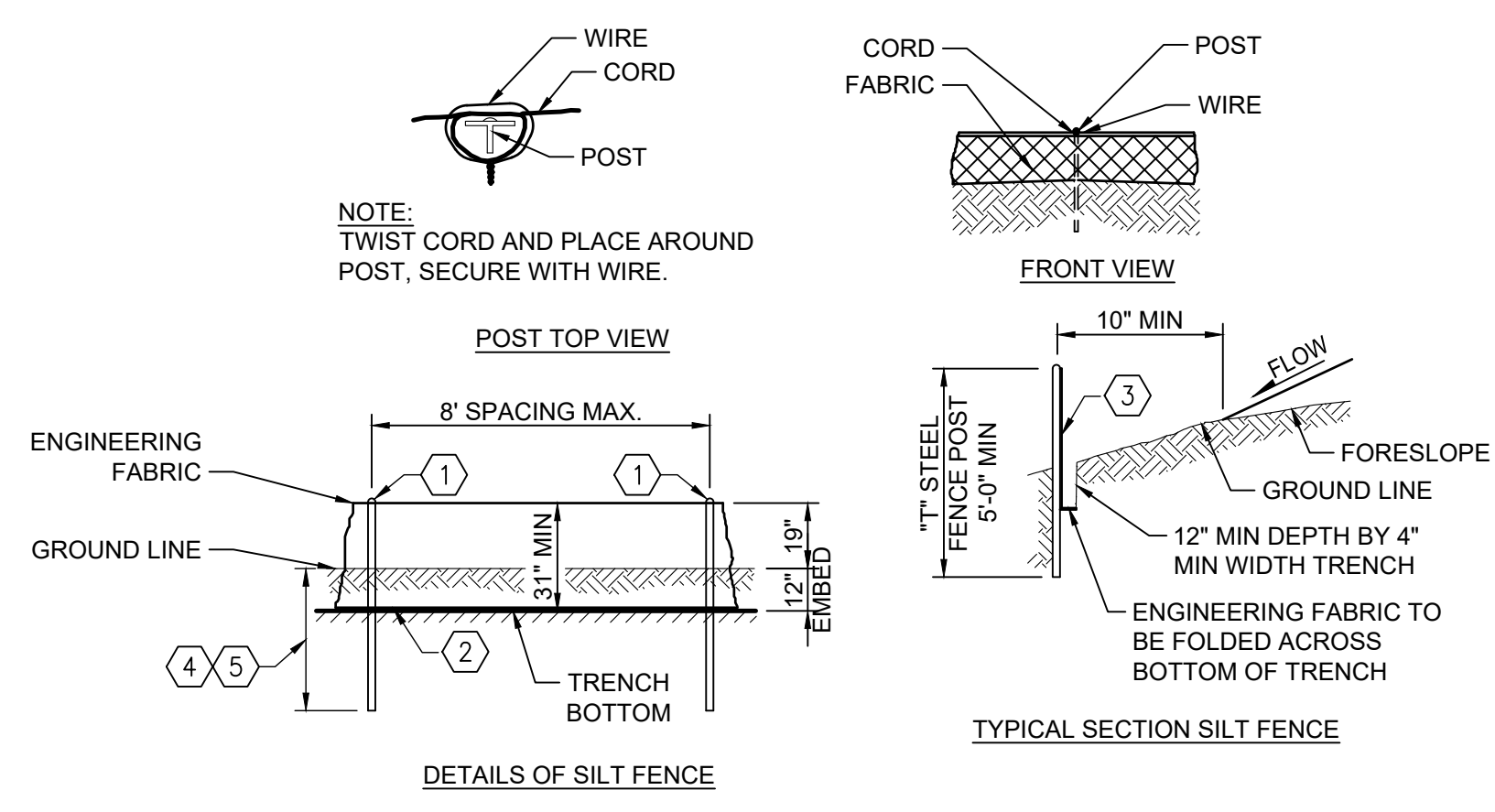

D4 SILT FENCE  
NOT TO SCALE

- GENERAL NOTES:
1. SECURE TOP OF ENGINEERING FABRIC TO STEEL POST.
  2. ENGINEERING FABRIC TO BE FOLDED ACROSS BOTTOM OF TRENCH.
  3. ENGINEERING FABRIC SHALL HAVE A MINIMUM 36" WIDTH.
  4. FOR MACHINE INSTALLATION, POSTS SHALL BE EMBEDDED 28" BELOW GROUND LINE. ALL COMPACTION SHALL BE ACCOMPLISHED BY DRIVING OVER EACH SIDE OF SILT FENCE 2-4 TIMES WITH DEVICE EXERTING 60PSI OR GREATER.
  5. FOR TRENCH INSTALLATION, POSTS SHALL BE EMBEDDED 28" BELOW THE TRENCH BOTTOM. ALL COMPACTION SHALL BE ACCOMPLISHED WITH A MECHANICAL OR PNEUMATIC TAMPER.

A4 WELL PROFILE  
NOT TO SCALE

P:\Projects\2023\20230105\20230105\Drawings\1\_Civil\Well #7 - Phase 2 Well and Pump\DWG\Construction Details.dwg  
Printed: 12/20/2023 4:33:51 PM

---

---

**LETTER OF RESIGNATION**

---

---

December 16<sup>th</sup>, 2023

Camanche Police Department  
819. S. Washington Blvd  
Camanche, IA 52730

Dear Chief Schmitz,

Effective immediately 12/16/23, I am resigning from the Camanche Police Department.

Thank you,

Joe Tyson

A handwritten signature in blue ink, appearing to read "Joe Tyson", with a long horizontal flourish extending to the right.

Resolution No. \_\_\_\_\_

**A RESOLUTION ESTABLISHING A POLICY FOR THE SELLING OF RIGHT OF WAY ON PUBLIC AVENUES  
WHERE 100 FOOT RIGHT OF WAY EXISTS**

**Whereas**, the City of Camanche, Iowa has a number of 100 foot Right of Way (ROW) Avenues as established in older platted developments in the city; and

**Whereas**, the City of Camanche, Iowa has determined that normally a 60 foot ROW is sufficient for residential subdivisions; and

**Whereas**, the City of Camanche, Iowa has determined it may be in the City's best interest to allow for the sale of a portion of the existing ROW to the adjacent property owner at an established price.

**Now, Therefore, Be It Resolved:** The Policy for the sale of Right of Way on an Avenue where a 100 foot Right of Way exists is hereby established as follows:

1. The sale of land may be offered to the adjoining property owner.
2. The sale price will be calculated at \$0.50 per square foot.
3. The sale must include no less and no more than 20 feet for the entire length of the property.
4. The buyer shall pay all publication fees, legal fees, survey work, recording fees, and any other fees or costs incurred by the City of Camanche in order to sell said Right of Way and comply with the requirements of State Law.
5. The buyer shall enter into a legal agreement with the City upon request to purchase thereby obligating the buyer to pay all fees and costs incurred by the City even if the transaction is not completed.
6. This policy will not apply if the City Council, in its reasonable discretion, determines retaining ROW serves the City's best interest.

Adopted by the Camanche City Council this \_\_\_\_\_ day of \_\_\_\_\_, 2020.

\_\_\_\_\_  
Attest: Toni L. Schneider, City Clerk

\_\_\_\_\_  
Paul Varner, Mayor Pro Tem

# MONTHLY REPORT

## NOVEMBER 2023

### CAMANCHE POLICE DEPARTMENT



Monthly Statistics		3 yr. Average
Squad Miles Driven	3120	5881
Monthly Calls for Service	598	895
Annual Calls for Service	9056	10,751
New Cases	19	26.4
Ambulance/FD Assists	37	57.3
MV Collisions	11	5.58
Arrests	8	9.80
Traffic Stops	53	84.8
Citations	16	29.11
Warnings/Memos	39	54.13
Mutual Aid *	34	29
SIFA Logged	391	558.6

#### Self-Initiated Field Activity

Business checks  
Citizen assists  
Community policing  
Foot patrol  
Found property  
Out with vehicle  
School checks  
Subject stops  
Suspicious subjects  
Suspicious vehicles  
Traffic stops  
Etc.

Mutual Aid calls are both to and from other agencies and reflect the total number of officers involved. For example, if two Camanche Officers are dispatched to assist the Clinton County Sheriff's Office that would account for two mutual aid calls. The average is based on 2022 statistics.



## Investigations & Patrol

---

- CAP23000258 – On 11/02/23 CAPD took a criminal mischief report from a resident in the 900 block of 9<sup>th</sup> Street where a window to the residence was damaged.
- CAP23000259 – On 11/02/23 CAPD conducted a traffic stop for an equipment violation on Highway 67 at Industrial Park Dr. Chayse Montana Grell (19) was subsequently arrested and charged with possession of marijuana and possession of drug paraphernalia while Reagan Michael Wilson (19) was arrested and charged with possession of marijuana.
- CAP23000260 – On 11/03/23 CAPD took a runaway report from a resident in the 900 block of 8<sup>th</sup> Ave regarding a minor child.
- CAP23000261 – On 11/03/23 CAPD investigated a two vehicle property damage only accident that occurred in the drive through at First gateway Credit Union, 2603 Industrial Park Dr.
- CAP23000262 – On 11/04/23 CAPD investigated a car vs. deer accident in the 3300 block of Anamosa Rd.
- CAP23000263 – On 11/08/23 CAPD conducted a traffic stop on a vehicle for speeding. The driver, Daniel M. Lyons (22) was subsequently arrested for OWI and possession of drug paraphernalia. Lyons was also cited for no insurance, no driver's license, and speeding.
- CAP23000264 – On 11/10/23 CAPD investigated a two vehicle PD accident in the Camanche High School parking lot.
- CAP23000265 – On 11/11/23 CAPD took a theft report from a resident in the 1900 block of 9<sup>th</sup> Ave regarding items taken from a construction trailer parked near Hwy 67 & 9<sup>th</sup> Ave.
- CAP23000266 – On 11/11/23 CAPD conducted a traffic stop on Hwy 67 at Industrial Park Drive for an equipment violation. The driver, Austin Michael Dykstra (26) was cited for possession of marijuana 2<sup>nd</sup> offense and possession of drug paraphernalia. Dykstra was issued a warning for the equipment violation.
- CAP23000267 – On 11/13/23 CAPD took a report from a resident in the 1200 block of 7<sup>th</sup> Ave in reference to a burglary to a motor vehicle where a several items valued at \$1038.99.
- CAP23000268 – On 11/16/23 CAPD was dispatched to the 500 block of 7<sup>th</sup> Ave for two female fighting. Isabel Marie Nocelotl (21) and Adrianna Nichole Pladna (19) were subsequently arrested for public intoxication.
- CAP23000269 – On 11/18/23 CAPD responded to a car vs. deer accident on Hwy 67 near 9<sup>th</sup> Street. No injuries reported.
- CAP23000270 – On 11/18/23 CAPD conducted a traffic stop on a vehicle for an equipment violation. The driver, Alexa Nicole Devries (25) was cited for possession of marijuana 1<sup>st</sup>, no insurance and given a written warning for the equipment violation.
- CAP23000271 – On 11/20/23 CAPD opened an investigation into messages left on a white board in one of the classrooms at the Camanche High School harassing staff.





## Investigations & Patrol

---

- CAP23000273 – On 11/25/23 CAPD conducted a traffic stop in the 1400 block of N. Washington Blvd for failing to obey a traffic control device. The driver, Jordan Douglas Gheer-Bertrand (35) was subsequently arrested for OWI 1<sup>st</sup> offense and issued a citation for failure to obey a traffic control device and no insurance.
- CAP23000274 – On 11/27/23 CAPD investigated a two vehicle property damage only accident that occurred in the roundabout on Highway 67/7<sup>th</sup> Ave.
- CAP23000275 – On 11/28/23 CAPD investigated a two vehicle accident in the 900 block of 7<sup>th</sup> Ave where a vehicle struck a parked car. The driver, Barri William Kooi (60) was cited for failure to maintain control.
- CAP23000276 – On 11/28/23 CAPD was dispatched to a residence in the 100 block of 21<sup>st</sup> Street for a domestic call.
- CAP23000277 – On 11/29/23 CAPD investigated a burglary/theft complaint from a residence in the 700 block of 6<sup>th</sup> Street where several items were taken, a window to the residence broken and a door jam was damaged.



# Statistical Crime Mapping

## November 2023 Case Reports by Location

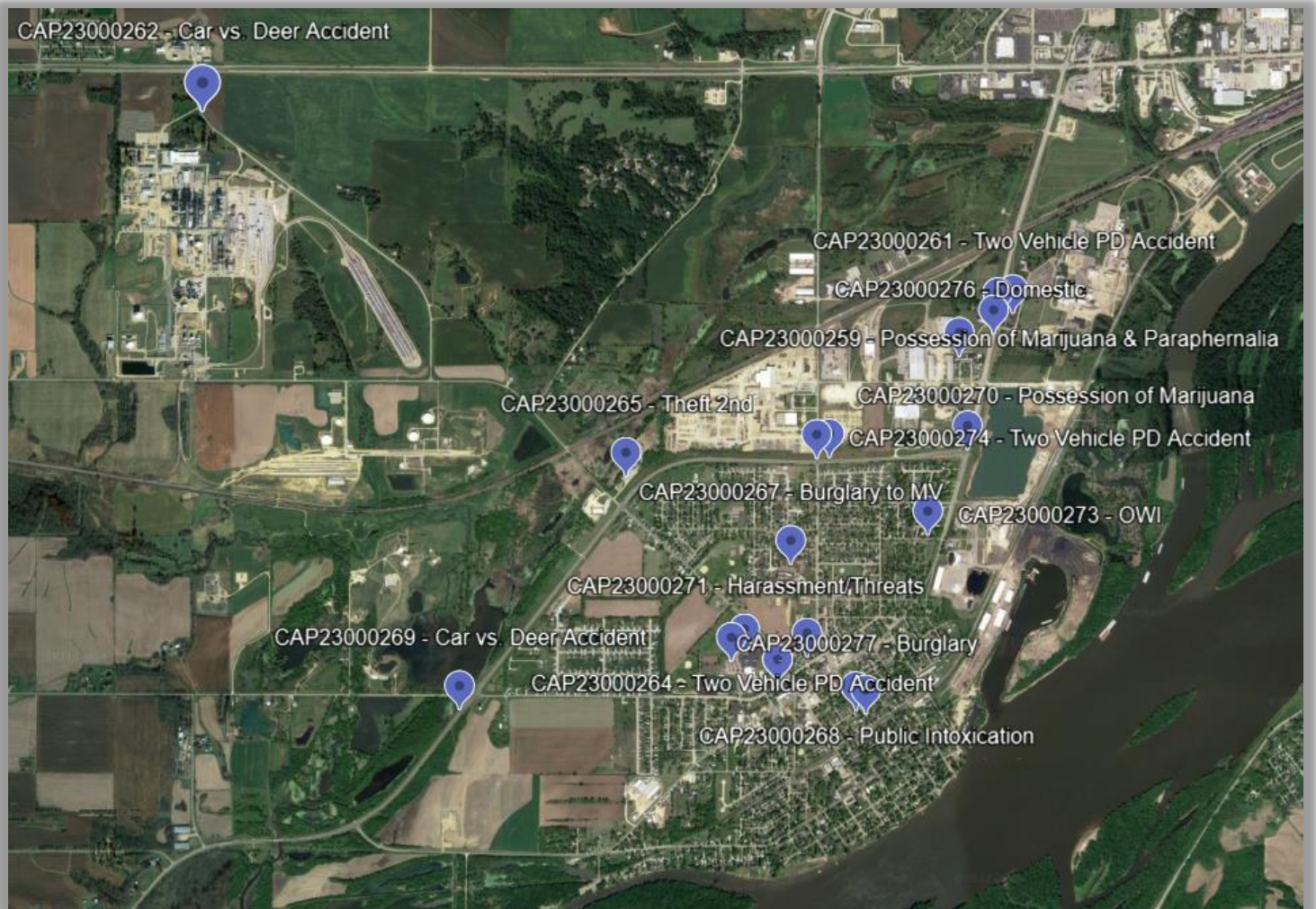

## Staffing

---

	Hours
Vacation	134
Personal Time	2
Sick Time	10
Bereavement	0
Overtime	99.25
Court 1.5x	0
Court 2x	10
Comp Time Earned	15.5



# Social Media

Cpl. Elliott's weather updates, traffic tips, etc. on our Facebook page.

**Chapter 1 Animal Control**  
4-1-3 License--Tag Required

Written original applications for licenses shall be made to the City Clerk which shall include name and address of owner, description, breed and sex of the dog or cat, the appropriate fee, and rabies certification issued by a licensed veterinarian and anti-rabies clinic. Second and subsequent applications for the same animal may be made orally at City Hall. The licensee, upon procurement of the license, shall securely attach the license tag to a collar or harness, and this collar or harness with the license tag attached shall at all times be kept on the dog or cat for which the license is issued. Any dog or cat found without a collar or harness to which a licensed tag is attached shall be deemed unlicensed, and shall be impounded.

Any person shall not own, keep, possess, shelter, or harbor more than four dogs and cats of one specie and no more than a total of four dogs and cats permitted per street address.



Animal at Large take-a-ways:  
Keep your pets (CATS and DOGS) contained; either on a leash or in a fenced in area to keep them and the public safe.  
Keep your chickens in a rear fenced in area on your property.

**Chapter 1 Animal Control**  
4-1-34 At Large--Permitting Unlawful

"At large" includes any dog or cat off the premises of its owner or upon the public streets, alleys, public grounds, school grounds, or parks within the City. The fact that a dog or cat is running at large without the knowledge or permission of the owner of such dog or cat is not a defense to any charge of the violation of this section. A dog or cat shall not be deemed at large if:

- a. It is attached to a leash of sufficient strength to restrain the dog or cat and not more than ten feet in length, where said leash is held by a person competent to govern the dog or cat; or
- b. When properly restrained within a motor vehicle or housed in an animal hospital approved by the City health officers; or
- c. Accompanied by and completely under the restraint of the owner or a competent, responsible person.

**4-1-37 A Keeping of Domestic Fowl and Livestock**

Domestic fowl or livestock must be kept in an enclosure and are not allowed to run at large on a property or within the community.

Chickens may be kept on single family residential properties in the City of Camanche. The number of chickens kept on residentially zoned properties shall be limited to no more than six chickens. Chickens may be kept in the rear yard only.



Camanche Police Department  
November 23 at 6:01 AM



From our table to yours  
*Happy Thanksgiving*

Camanche Police Department  
November 18 at 7:39 PM

Did you know Camanche Police Department offers several employment incentives? - Annually, we offer \$250 to our Officers to spend on any wellness related expense.



- ✓Gym memberships
- ✓Gym equipment... See more

**DO YOU KNOW?**

CAMANCHE PD PAYS \$250 ANNUALLY FOR ANY WELLNESS OR FITNESS RELATED EXPENSE

**OFFICER PARKS**

"I use my wellness bonus for workout clothes from Lululemon, running gear, or running shoes!"

Camanche Police Department  
November 29 at 6:39 PM

It is with great sadness that we mourn the loss of Gerald R. Edwards (Jerry) who was the longest serving Chief of the Camanche Police Department. We thank you for your dedicated service to Camanche Police Department and the citizens of this community. May you rest in eternal peace.



Camanche Police Department  
2d

We need your help. Rylan Schultz has been reported as a runaway multiple times over the past 6 months; with the last incident reported October 6, 2023. He has not returned home. We believe that he is staying with someone; but we have not received any information on his whereabouts. Do you know where Rylan is? Please contact the Camanche Police Department at 563-259-8575; or message us on Facebook.



Camanche Police Department  
November 22 at 7:11 PM

Congratulations to these students; they were "Caught Doing a Good Deed!" Way to go!

*Caught doing a good deed*



BRINLYNN LAWRENCE

KENNEDY SCHWARTZ

**CAMANCHE STORM**

4-1-7 License- Fee- Designated. A license shall be issued after submission of the written application, rabies certification, and after payment of the following applicable fees:

1. For each unneutered male dog.....\$6.00
2. For each unneutered male cat.....\$6.00
3. For each unspayed female dog.....\$6.00
4. For each unspayed female cat.....\$6.00
5. For each neutered male dog.....\$3.00
6. For each neutered male cat.....\$3.00
7. For each spayed female dog.....\$3.00
8. For each spayed female cat.....\$3.00

4-1-8 LICENSE--DUE DATE. A dog or cat must be licensed by March 31st of each year, or at the time a dog or cat comes into possession or ownership. All dogs and cats must be licensed by the time they reach six months of age.

Camanche Police Department  
4d

Have you ever wondered what the Iowa Law Enforcement Academy is like? During 16-weeks, recruits will complete 636 hours of instruction and hands on training, including: Firearms, Driving Operations, Drug Crimes and Meth Labs, Gangs, Felony Calls, Defensive Tactics, and so much more! ... See more



Camanche Police Department is at Scott Community College.  
3d · Bettendorf

Join us at Scott Community College for the Criminal Justice Career Fair in the Belmont Campus. We're here until 1 P.M.

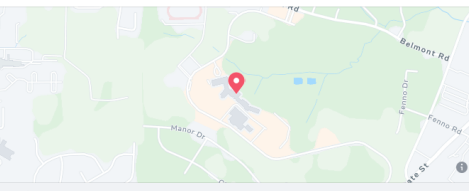

COMMUNITY COLLEGE  
**Scott Community College**  
Greg has been here

Camanche Police Department  
November 17 at 10:00 AM

Camanche Police Department is now accepting applications for the position of Police Officer! Application packets, physical fitness testing information, as well as a list of benefits and incentives may be obtained online at [www.camancheia.org](http://www.camancheia.org), by calling Camanche City Hall (563) 259-8342, in person at Camanche Police Department, or by email.

Qualification & Requirements:  
High School Diploma or G.E.D.... See more

**APPLY TODAY**

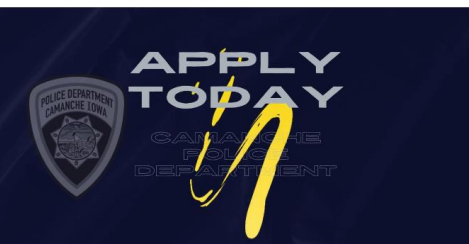

## Community Outreach



On 11/02/23, Lone Star Transportation, LLC, who facilitated the wind turbine blades this fall, donated \$1000 to the Friends of Camanche Police 501C3.



Your Pet, Our Passion.®

Purina donated 5 bags of dog food to the animal control program.



## Training & Equipment - (49 hours of training in November)

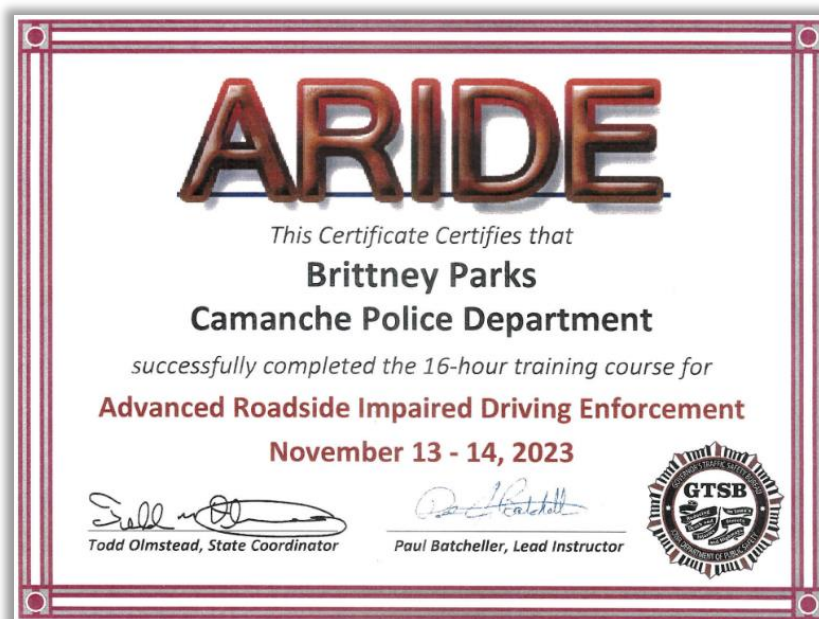

# Training & Equipment

**LEXIPOL**

## CERTIFICATE OF ATTENDANCE

THIS CERTIFICATE IS AWARDED TO **Bill Lodge**

FOR ATTENDING THE WEBINAR **Risk vs Reward: Effecting a Safe Traffic Stop in Today's Policing Environment [70 minutes]**

November 8, 2023

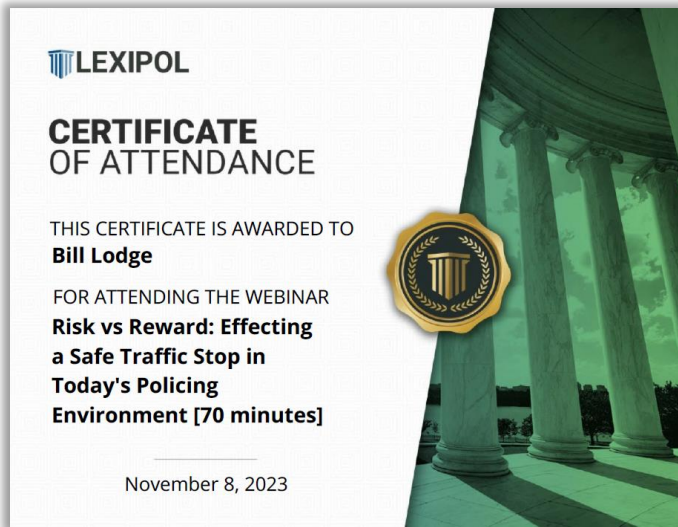

**LEXIPOL**

## CERTIFICATE OF ATTENDANCE

THIS CERTIFICATE IS AWARDED TO **Bill Lodge**

FOR ATTENDING THE WEBINAR **6 Leadership "Watchouts" for Public Safety Leaders [90 minutes]**

November 1, 2023



**POLICEONE ACADEMY**

## CERTIFICATE OF COMPLETION

AWARDED TO

**RICH SCHMITZ**

OF CAMACHE POLICE DEPARTMENT (IA)  
IN RECOGNITION OF YOUR SUCCESSFUL COMPLETION OF  
**IDENTITY THEFT CRIMES**  
COURSE # INVS105  
3 HOURS OF TRAINING  
CERTIFICATE ISSUED NOV 22, 2023

*Mikayla Graves*  
Mikayla Graves  
Director of Training



**POLICEONE ACADEMY**

## CERTIFICATE OF COMPLETION

AWARDED TO

**ANDREW MICHAEL WEINGART**

OF CAMACHE POLICE DEPARTMENT (IA)  
IN RECOGNITION OF YOUR SUCCESSFUL COMPLETION OF  
**PRESENTING EFFECTIVE TESTIMONY IN A COURTROOM**  
COURSE # 23560-2301  
1 HOUR OF TRAINING  
CERTIFICATE ISSUED NOV 14, 2023

*Mikayla Graves*  
Mikayla Graves  
Director of Training

IADLEST  
Certified



**LEXIPOL**

## CERTIFICATE OF ATTENDANCE

THIS CERTIFICATE IS AWARDED TO **Bill Lodge**

FOR ATTENDING THE WEBINAR **Moral Injury: What Is It and What Can We Do About It [90 minutes]**

November 16, 2023

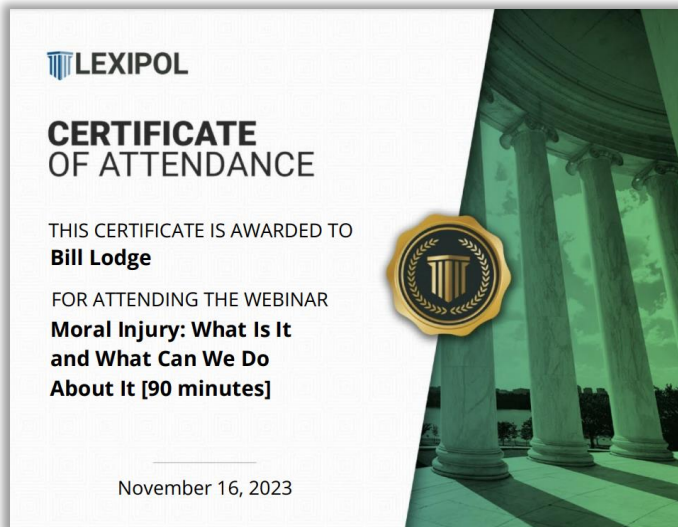

## CERTIFICATE

PROUDLY PRESENTED TO

Bill Lodge

The path to Drone as First Responder: Scaling drone programs for public safety agencies

Nov. 9, 2023      Lexipol

Date of Completion      Organizer

